

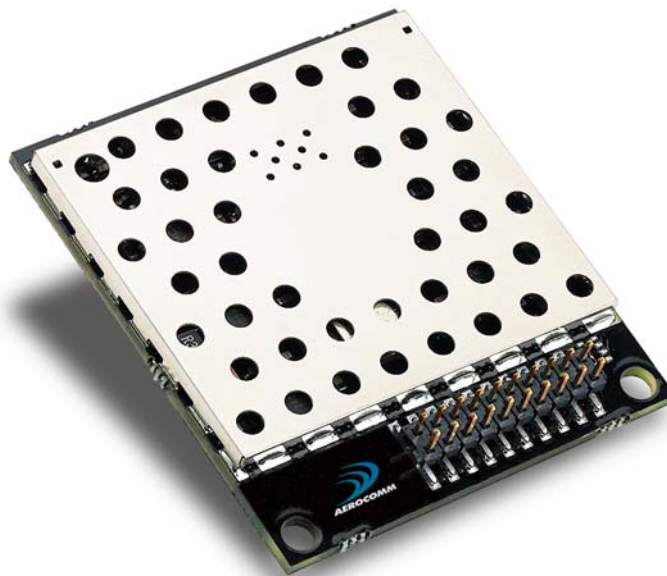

AC4486
868 MHz OEM TRANSCEIVERS

Specifications Subject to Change

User's Manual
Version 1.8



10981 EICHER DRIVE
LENEXA, KS 66219
(800) 492-2320
www.aerocomm.com
wireless@aerocomm.com

DOCUMENT INFORMATION

Copyright Information

Copyright © 2004 AEROCOMM, Inc. All rights reserved. The information contained in this manual and the accompanying software programs are copyrighted and all rights are reserved by AEROCOMM, Inc. AEROCOMM, Inc. reserves the right to make periodic modifications of this product without obligation to notify any person or entity of such revision. Copying, duplicating, selling, or otherwise distributing any part of this product or accompanying documentation/software without the prior consent of an authorized representative of AEROCOMM, Inc. is strictly prohibited.

All brands and product names in this publication are registered trademarks or trademarks of their respective holders.

This material is preliminary

Information furnished by AEROCOMM in this specification is believed to be accurate. Devices sold by AEROCOMM are covered by the warranty and patent indemnification provisions appearing in its Terms of Sale only. AEROCOMM makes no warranty, express, statutory, and implied or by description, regarding the information set forth herein. AEROCOMM reserves the right to change specifications at any time and without notice.

AEROCOMM's products are intended for use in normal commercial and industrial applications. Applications requiring unusual environmental requirements such as military, medical life-support or life-sustaining equipment are specifically not recommended without additional testing for such application.

Limited Warranty, Disclaimer, Limitation of Liability

For a period of one (1) year from the date of purchase by the OEM customer, AeroComm warrants the OEM transceiver against defects in materials and workmanship. AeroComm will not honor this warranty (and this warranty will be automatically void) if there has been any (1) tampering, signs of tampering; 2) repair or attempt to repair by anyone other than an AeroComm authorized technician.

This warranty does not cover and AeroComm will not be liable for, any damage or failure caused by misuse, abuse, acts of God, accidents, electrical irregularity, or other causes beyond AeroComm's control, or claim by other than the original purchaser.

In no event shall AeroComm be responsible or liable for any damages arising: From the use of product; From the loss of use, revenue or profit of the product; or As a result of any event, circumstance, action, or abuse beyond the control of AeroComm, whether such damages be direct, indirect, consequential, special or otherwise and whether such damages are incurred by the person to whom this warranty extends or third party.

If, after inspection, AeroComm determines that there is a defect, AeroComm will repair or replace the OEM transceiver at their discretion. If the product is replaced, it may be a new or refurbished product.

DOCUMENT INFORMATION

<u>Revision</u>	<u>Description</u>
Version 1.0	3/15/2002 – Initial Release Version
Version 1.1	12/18/2002 – Preliminary Release
Version 1.2	12/20/2002 – Preliminary Release. Changed location of new interface pins for higher compatibility with AC4424 product family.
Version 1.3	1/29/2003 – Updated interface baud rate formula/table. Updated current consumption table. Corrected RSSI plot. Updated Interface Timeout information. Renamed product family to AC4490. Multiple byte EEPROM read/write now allowed.
Version 1.4	2/18/2003 – Added Max Power byte. Removed Write Enable references. Fixed Power Down/Up command response. Removed Peer-to-Peer bit. Added Auto Destination. Added Unicast Only bit. Added 500mW product. Revised part numbers. Updated Channel Number settings.
Version 1.5	Not released.
Version 1.6	11/07/2003 – Added One Beacon and modem modes. Included AC4486 product line. Added 500mW specifications. Updated part numbers. Added AT Commands. Eliminated Commercial designation: All transceivers are now industrial qualified.
Version 1.7	7/09/04 – Changed Range Refresh so that 0h is an invalid setting. Updated AC4490 500mW output power (conducted and EIRP). Added warranty information. Changed AC4490-500 part number to AC4490-1000. Removed support of One Beacon Mode. Added DES.
Version 1.8	12/08/04 – Changed minimum Interface Timeout @ 19,200 baud to 3. Added support for One Beacon Mode. Added on-the-fly Read Temperature command. Added on-the-fly EEPROM read/write commands. Removed AC4490 product information.

TABLE OF CONTENTS

1.	OVERVIEW	7
2.	AC4486 SPECIFICATIONS	8
3.	SPECIFICATIONS	9
3.1	INTERFACE SIGNAL DEFINITIONS	9
3.2	ELECTRICAL SPECIFICATIONS.....	10
3.3	SYSTEM TIMING AND LATENCY	11
3.3.1	<i>Serial Interface Data Rate</i>	11
3.3.2	<i>Latency</i>	11
3.3.3	<i>Timing Diagrams</i>	12
3.3.4	<i>Maximum Overall System Throughput</i>	14
4.	CONFIGURING THE AC4486.....	15
4.1	EEPROM PARAMETERS	15
4.2	CONFIGURATION FLOW OF THE AC4486	19
4.3	COMMAND QUICK REFERENCE.....	20
4.4	EEPROM CONFIGURATION COMMANDS	22
4.4.1	<i>EEPROM Byte Read</i>	22
4.4.2	<i>EEPROM Byte Write</i>	22
4.4.3	<i>EEPROM Exit Configuration Mode Command</i>	23
4.5	AC4486 AT COMMANDS	23
4.5.1	<i>Enter AT Command Mode</i>	23
4.5.2	<i>AT Enter Configuration Mode</i>	24
4.5.3	<i>Exit AT Command Mode</i>	24
4.6	ON-THE-FLY CONTROL COMMANDS (CC COMMAND MODE)	24
4.6.1	<i>Status Request</i>	25
4.6.2	<i>Change Channel without Forced Acquisition Sync</i>	25
4.6.3	<i>Change Channel with Forced Acquisition Sync</i>	25
4.6.4	<i>Server/Client Command</i>	26
4.6.5	<i>Sync to Channel Command</i>	26
4.6.6	<i>Sleep Walk Power-Down Command</i>	27
4.6.7	<i>Sleep Walk Power-Down Wake-Up Command</i>	27
4.6.8	<i>Broadcast Mode</i>	27
4.6.9	<i>Read Static Bank #1 Byte</i>	28
4.6.10	<i>Write Static Bank #1 Byte</i>	28
4.6.11	<i>Read Static Bank #2 Byte</i>	28
4.6.12	<i>Write Static Bank #2 Byte</i>	30
4.6.13	<i>Write Destination Address</i>	30
4.6.14	<i>Read Destination Address</i>	30
4.6.15	<i>Auto Destination</i>	31
4.6.16	<i>Read Digital Inputs</i>	31
4.6.17	<i>Read ADC</i>	32
4.6.18	<i>Report Last Valid RSSI</i>	33
4.6.19	<i>Write Digital Outputs</i>	34
4.6.20	<i>Write DAC</i>	34
4.6.21	<i>Set Max Power</i>	35
4.6.22	<i>Transmit Buffer Empty</i>	35
4.6.23	<i>Disable Sync to Channel</i>	35
4.6.24	<i>Deep Sleep Mode</i>	36
4.6.25	<i>Read Temperature</i>	36
4.6.26	<i>EEPROM Byte Read</i>	36

4.6.27	EEPROM Byte Write	37
4.6.28	Reset Command	37
5.	THEORY OF OPERATION	38
5.1	HARDWARE INTERFACE.....	38
5.1.1	GIn (Generic Inputs 0 and 1) (pins 4 and 14 respectively) and GOn (Generic Outputs 0 and 1) (pins 1 and 9 respectively).....	38
5.1.2	TXD (Transmit Data) and RXD (Receive Data) (pins 2 and 3 respectively).....	38
5.1.3	Hop Frame (pin 6).....	38
5.1.4	CTS Handshaking (pin 7).....	39
5.1.5	RTS Handshaking (pin 8).....	39
5.1.6	9600 Baud (pin 12).....	39
5.1.7	RSSI (pin 13).....	39
5.1.8	UP_Reset (pin 15).....	40
5.1.9	Command/Data (pin 17).....	40
5.1.10	AD In and DA Out (pins 18 and 19 respectively).....	41
5.1.11	In Range (pin 20).....	41
5.2	SOFTWARE PARAMETERS	42
5.2.1	RF Architecture (Unicast/Broadcast).....	42
5.2.2	RF Mode	42
5.2.3	Sub Hop Adjust	43
5.2.4	Duplex Mode	43
5.2.5	Interface Timeout/RF Packet Size.....	43
5.2.6	Serial Interface Baud Rate.....	44
5.2.7	Network Topology.....	44
5.2.8	Auto Config.....	45
5.2.9	One Beacon Mode	46
5.2.10	Max Power.....	47
	Interface Options.....	48
6.	DIMENSIONS	49
7.	ORDERING INFORMATION.....	51
7.1	PRODUCT PART NUMBER TREE	51
7.2	DEVELOPER KIT PART NUMBERS	51
8.	AGENCY COMPLIANCY INFORMATION	52
8.1	APPROVED ANTENNA LIST	52
8.2	OEM EQUIPMENT LABELING REQUIREMENTS	52
8.3	COUNTRY RESTRICTIONS	53
8.4	COUNTRY NOTIFICATION	53
8.5	DECLARATIONS OF CONFORMITY	53

Figures

Figure 1 – RSSI Voltage vs. Received Signal Strength.....	40
Figure 2 - AC4486 (with MMCX Connector) Mechanical	49
Figure 3 - AC4486 (with Integral Splat Antenna) Mechanical.....	50

Tables

Table 1 – Pin Definitions.....	9
Table 2 – Input Voltage Characteristics (AC4486-500).....	10
Table 3 – Input Voltage Characteristics (All Others).....	10
Table 4 – Output Voltage Characteristics (All).....	10
Table 5 – Supported Serial Formats	11

Table 6 – Timing Parameters.....	14
Table 7 – Maximum Overall System Throughputs	14
Table 8 – EEPROM Parameters	15
Table 9 – Baud Rate/Interface Timeout.....	44
Table 10 – US and International RF Channel Number Settings.....	45
Table 11 – Auto Config Parameters	46
Table 12 – One Beacon Mode Settings	46
Table 13 – Max Power Settings for AC4486-5 Transmitter.....	47
Table 14 – Transceiver Interface to DCE (Server Transceiver)	48
Table 15 – Transceiver Interface to DTE (Client Transceiver)	48
Table 16 – CE Approval Status	52
Table 17 – AC4486 Approved Antenna List.....	52
Table 18 – Restrictions.....	53

AC4486 Features

- ✓ Drop-in replacement for AC4490 and AC4424 product families
- ✓ Two generic input and output digital lines and integrated DAC/ADC functions
- ✓ Cost Efficient for high volume applications
- ✓ Very low power consumption for battery powered implementations
- ✓ Small size for portable and enclosed applications
- ✓ Very Low latency and high throughput
- ✓ All modules are qualified for Industrial temperatures (-40°C to 80°C)

1. Overview

The AC4486 is a member of AeroComm's ConnexRF OEM transceiver family. The AC4486 is designed for integration into OEM systems operating under European ETSI regulations for the 868 - 870 MHz band.

The AC4486 is a cost-effective, high performance, spread spectrum transceiver. It provides an asynchronous TTL/RS-485 level serial interface for OEM Host communications. Communications include both system and configuration data. The Host supplies system data for transmission to other Host(s). Configuration data is stored in an on-board EEPROM. All RF system data transmission/reception is performed by the transceiver.

These transceivers can be used as a direct serial cable replacement – requiring no special Host software for operation. They also feature a number of On-the-Fly Control Commands providing the OEM with a very versatile interface for any network.

AC4486 transceivers operate in a Point-to-Point or Point-to-Multipoint, Client-Server or Peer-to-Peer architecture. One transceiver is configured as a Server and there can be one or many Clients. To establish synchronization between transceivers, the Server emits a beacon. Upon detecting a beacon, a Client transceiver informs its Host and a RF link is established.

This document contains information about the hardware and software interface between an AeroComm AC4486 transceiver and an OEM Host. Information includes the theory of operation, specifications, interface definition, configuration information and mechanical drawings.

The OEM is responsible for ensuring the final product meets all appropriate regulatory agency requirements listed herein before selling any product.

2. AC4486 Specifications

GENERAL																											
20 Pin Interface Connector	Samtec TMM-110-01-L-D-SM, mates with Samtec SMM-110-02-S-D																										
RF Connector	Telegärtner J01341C0081, mates with any manufacturer's MMCX style plug																										
Antenna	AC4486-5: MMCX Connector or integral antenna AC4486-500: MMCX Connector																										
Serial Interface Data Rate	Baud rates from 1200 bps to 115,200 bps																										
Power Consumption (typical)	<p style="text-align: center;">Duty Cycle (TX=Transmit; RX=Receive)</p> <table border="1" style="width: 100%; border-collapse: collapse;"> <thead> <tr> <th></th> <th>10%TX</th> <th>50%TX</th> <th>100%TX</th> <th>100%RX</th> <th>Pwr-Down</th> <th>Deep Sleep</th> </tr> </thead> <tbody> <tr> <td>AC4486-5:</td> <td>31mA</td> <td>35mA</td> <td>40mA</td> <td>30mA</td> <td>19mA</td> <td>6mA</td> </tr> <tr> <td>AC4486-500:</td> <td>TBD</td> <td>TBD</td> <td>TBD</td> <td>TBD</td> <td>TBD</td> <td>TBD</td> </tr> </tbody> </table>							10%TX	50%TX	100%TX	100%RX	Pwr-Down	Deep Sleep	AC4486-5:	31mA	35mA	40mA	30mA	19mA	6mA	AC4486-500:	TBD	TBD	TBD	TBD	TBD	TBD
	10%TX	50%TX	100%TX	100%RX	Pwr-Down	Deep Sleep																					
AC4486-5:	31mA	35mA	40mA	30mA	19mA	6mA																					
AC4486-500:	TBD	TBD	TBD	TBD	TBD	TBD																					
Channels	2 Channels																										
Security	One byte System ID. 56 bit DES encryption key.																										
Interface Buffer Size	Input/Output: 256 bytes each																										
TRANSCEIVER																											
Frequency Band	Europe 5mW: 869.7 – 870 MHz Europe 500mW: 869.4 – 869.65 MHz																										
RF Data Rate	76.8kbps fixed																										
RF Technology	AC4486: Single Frequency FSK																										
Output Power					<u>EIRP (3dBi gain antenna)</u>																						
	AC4486-5: 2.5mW typical				5mW typical																						
	AC4486-500: TBD				TBD																						
Supply Voltage	AC4486-5: 3.3 – 5.5V, ±50mV ripple AC4486-500: Pin 10: 3.3 – 5.5V ±50mV ripple Pin 11: 3.3 ±3%, ±100mV ripple																										
Sensitivity	-100dBm typical @ 76.8kbps RF Data Rate																										
Range, Line of Site (based on 3dBi gain antenna)	AC4486-5: 3000 feet AC4486-500: TBD																										
ENVIRONMENTAL																											
Temperature (Operating)	-40°C to 80°C																										
Temperature (Storage)	-50°C to +85°C																										
Humidity (non-condensing)	10% to 90%																										
PHYSICAL																											
Dimensions	Transceiver with MMCX Connector:		1.65" x 1.9" x 0.20"																								
	Transceiver with Integral Antenna:		1.65" x 2.65" x 0.20"																								
Weight	Less than 0.75 ounce																										

3. Specifications

3.1 INTERFACE SIGNAL DEFINITIONS

The AC4486 has a simple interface that allows OEM Host communications with the transceiver. The table below shows the connector pin numbers and associated functions. The I/O direction is with respect to the transceiver. All outputs are 3.3VDC levels and inputs are 5VDC TTL (with the exception of AC4486-500 transceivers which are 3.3V inputs). All inputs are weakly pulled High and may be left floating during normal operation.

Table 1 – Pin Definitions

Pin	Type	Signal Name	Function
1	O	GO0	Generic Output pin
2	O	TXD	Transmitted data out of the transceiver
	I/O	RS485 A (True) ¹	Noninverted RS-485 representation of serial data
3	I	RXD	Data input to the transceiver
	I/O	RS485 B (Invert) ¹	Mirror image of RS-485 A
4	I	GI0	Generic Input pin
5	GND	GND	Signal Ground
6	O	Hop Frame	Pulses Low when the transceiver is hopping.
7	O	CTS	Clear to Send – Active Low when the transceiver is ready to accept data for transmission.
8	I	RTS	Request to Send – When enabled in EEPROM, the OEM Host can take this High when it is not ready to accept data from the transceiver. NOTE: Keeping RTS High for too long can cause data loss.
9	O	GO1	Generic Output pin
10	PWR	VCC1	AC4486-5: 3.3 – 5.5V, ±50mV ripple AC4486-500: 3.3 – 5.5V, ±50mV ripple
11	PWR	VCC2	AC4486-5: 3.3 – 5.5V, ±50mV ripple AC4486-500: 3.3V ±3%, ±100mV ripple
12	I	9600_BAUD	9600_BAUD – When pulled logic Low and then applying power or resetting, the transceiver’s serial interface is forced to a 9600, 8, N, 1 rate. To exit, transceiver must be reset or power-cycled with 9600_Baud logic High.
13	O	RSSI	Received Signal Strength - An analog output giving an instantaneous indication of received signal strength. Only valid while in Receive Mode.
14	I	GI1	Generic Input pin
15	I	UP_RESET	RESET – Controlled by the AC4486 for power-on reset if left unconnected. After a Stable power-on reset, a logic High pulse will reset the transceiver.
16	GND	GND	Signal Ground
17	I	Command/Data	When logic Low, the transceiver interprets Host data as command data. When logic High, the transceiver interprets Host data as transmit data.
18	I	AD In	10 bit Analog Data Input
19	O	DA Out	10 bit Analog Data Output
20	O	IN_RANGE	In Range – Active Low when a Client transceiver is in range of a Server on same Channel with the same System ID. Always Low on a Server.

I = Input to the transceiver O = Output from the transceiver

¹ When ordered with a RS-485 interface.

3.2 ELECTRICAL SPECIFICATIONS

Table 2 – Input Voltage Characteristics (AC4486-500)

Pin	Type	Name	High Min.	High Max.	Low Min.	Low Max.	Unit
2,3	I/O	RS485A/B	N/A	12	-7	N/A	V
3	I	RXD	2.31	3.3	0	0.99	V
4	I	GI0	2.31	3.3	0	0.99	V
8	I	RTS	2.31	3.3	0	0.99	V
12	I	9600 Baud	2.31	3.3	0	0.99	V
14	I	GI1	2.31	3.3	0	0.99	V
15	I	UP_RESET	0.8	3.3	0	0.6	V
17	I	Command/Data	2.31	3.3	0	0.99	V
18	I	AD In	N/A	3.3	0	N/A	V

Table 3 – Input Voltage Characteristics (All Others)

Pin	Type	Name	High Min.	High Max.	Low Min.	Low Max.	Unit
2,3	I/O	RS485A/B	N/A	12	-7	N/A	V
3	I	RXD	2	5.5	0	0.8	V
4	I	GI0	2	5.5	0	0.8	V
8	I	RTS	2	5.5	0	0.8	V
12	I	9600 Baud	2	5.5	0	0.8	V
14	I	GI1	2	5.5	0	0.8	V
15	I	UP_RESET	0.8	5	0	0.6	V
17	I	Command/Data	2	5.5	0	0.8	V
18	I	AD In	N/A	3.3	0	N/A	V

Table 4 – Output Voltage Characteristics (All)

Pin	Type	Name	High Min.	Low Max.	Unit
1	O	GO0	2.5 @ 8mA	0.4 @ 8mA	V
2	O	TXD	2.5 @ 2mA	0.4 @ 2mA	V
2,3	I/O	RS485A/B	3.3 @ 1/8 Unit Load	N/A	V
6	O	Hop Frame	2.5 @ 2mA	0.4 @ 2mA	V
7	O	CTS	2.5 @ 2mA	0.4 @ 2mA	V
9	O	GO1	2.5 @ 2mA	0.4 @ 2mA	V
13	O	RSSI	See Figure 1	See Figure 1	V
19	O	AD Out	N/A	N/A	V ²
20	O	IN_RANGE	2.5 @ 2mA	0.4 @ 2mA	V

² AD Out is an unbuffered, high impedance output and **must be buffered** by the OEM Host when used.

3.3 SYSTEM TIMING AND LATENCY

Care should be taken when selecting transceiver architecture as it can have serious effects on data rates, latency timings, and overall system throughput. The importance of these three characteristics will vary from system to system and should be a strong consideration when designing the system.

3.3.1 Serial Interface Data Rate

The Serial Interface Data Rate is programmable by the Host. This is the rate the Host and transceiver communicate over the serial bus. Possible values range from 1200 bps to 115,200 bps. **Note: Enabling Parity Mode cuts throughput in half and the Interface Buffer size in half.** The following asynchronous serial data formats are supported:

Table 5 – Supported Serial Formats

Data Bits	Parity	Stop Bits	Transceiver Programming Requirements
9	N	1	Parity Mode enabled
8	N	1	Parity Mode disabled
8	N	2	Parity Mode enabled
8	E,O,M,S	1	Parity Mode enabled
7	E,O,M,S	2	Parity Mode enabled
7	N	2	Parity mode disabled
7	E,O,M,S	1	Parity Mode disabled

3.3.2 Latency

Note about Timing: The AC4486 is a single frequency radio design. Though it does not hop from one frequency to another, packet delivery timing is based on a fictitious hop, which occurs every 20ms. This maximizes the use of the AC4486 resources and makes timing much more deterministic. For ease of understanding, the documentation will still refer to a hop. The Server will still send a timing beacon out every 1.2s to provide Clients with its MAC Address.

Acknowledge Mode

The transceiver will use Interface Timeout in conjunction with Fixed Packet Length (whichever condition occurs first) to determine a complete packet to be sent over the RF. If Full Duplex is enabled, the transceiver must wait for its appropriate hop (even numbered hops for the Server and odd numbered hops for the Client). Upon doing this, the transceiver will calculate the amount of time until the next hop to ensure that it has time to send the packet. If there is enough time, it will send the packet: if not, it will wait until its next appropriate hop. Transmit Retries and Broadcast Attempts are handled in the same manner.

Stream Mode

The transceiver will use Interface Timeout in conjunction with Fixed Packet Length (whichever condition occurs first) to determine a complete packet to be sent over the RF. Next, the transceiver will begin sending the packet. If a hop is scheduled to occur before the entire packet can be sent out, the

transceiver will send as much of the packet as it can prior to the hop and send the remainder of the packet after the hop.

3.3.3 Timing Diagrams

Stream Mode with Interface Timeout:

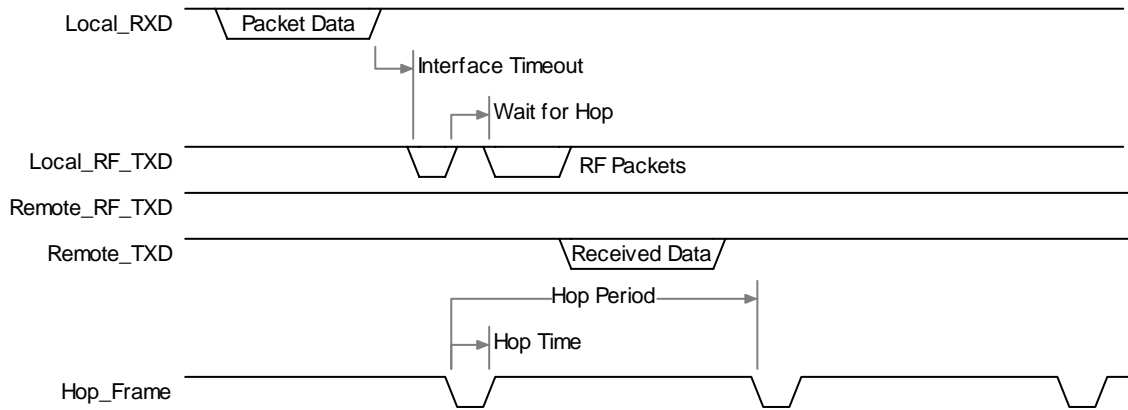

Stream Mode with Fixed Packet Length:

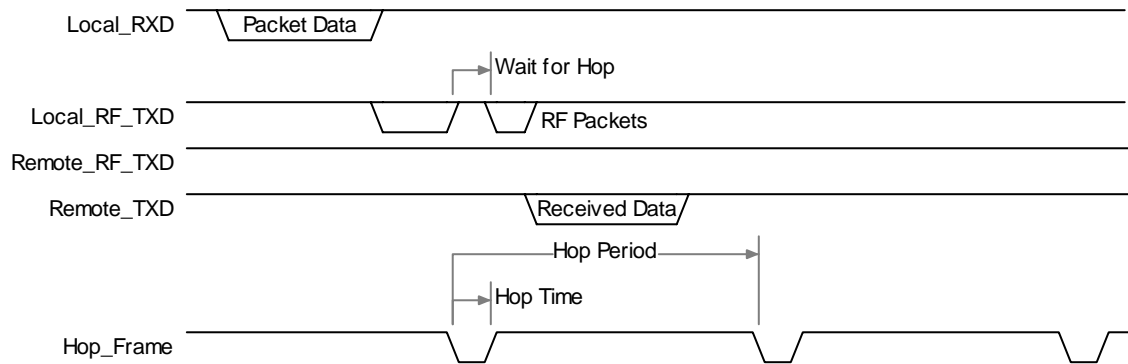

Addressed Acknowledge Mode with Interface Timeout:

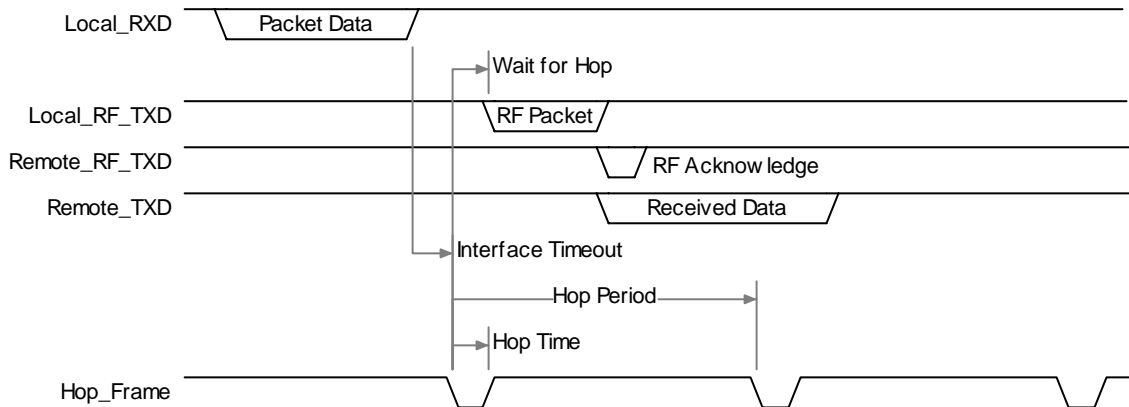

Addressed Acknowledge Mode with Fixed Packet Length:

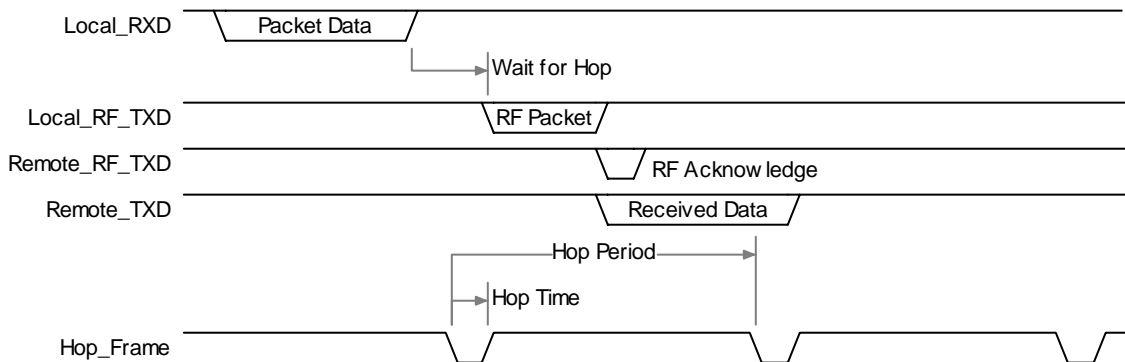

Broadcast Acknowledge Mode with Interface Timeout:

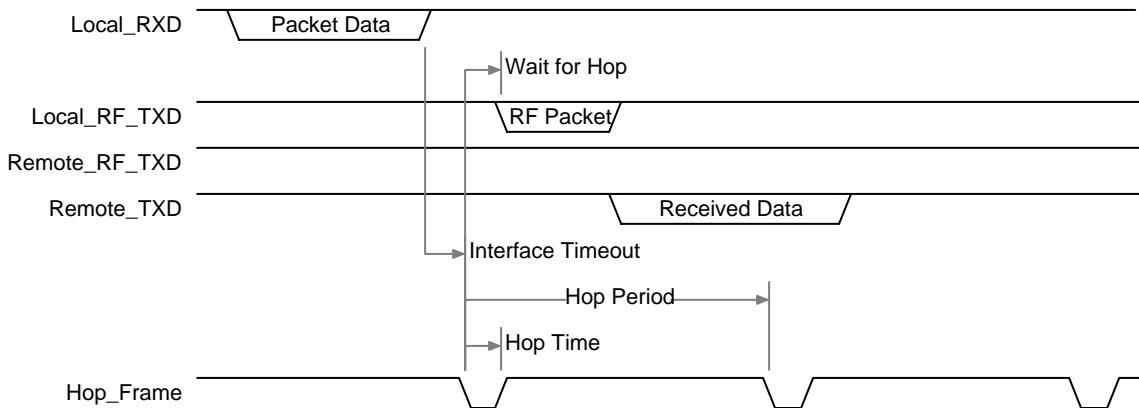

Broadcast Acknowledge Mode with Fixed Packet Length:

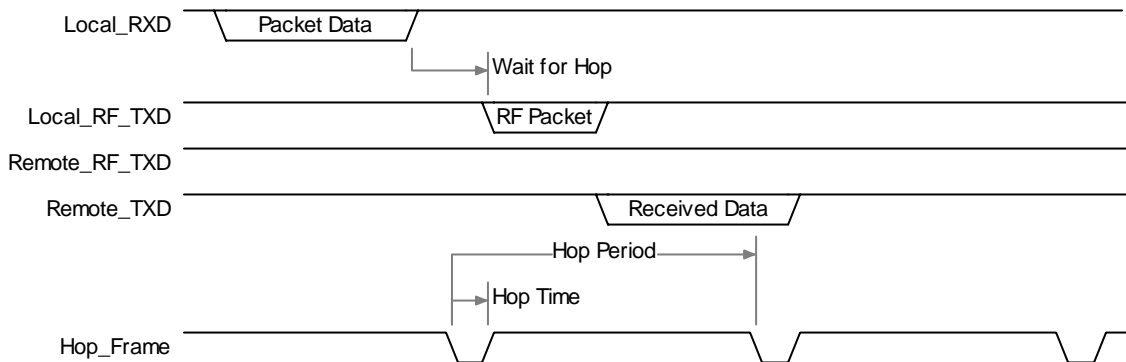

Table 6 – Timing Parameters

Parameter	Typical Time (ms)
Hop Time	0
Hop Period	20
Beacon Period	1200
Beacon Time	1

3.3.4 Maximum Overall System Throughput

When configured as shown in the table below, an AC4486 transceiver is **capable** of achieving the listed throughput. However, in the presence of interference or at longer ranges, the transceiver might not be able to meet these specified throughputs.

Table 7 – Maximum Overall System Throughputs

RF Mode	One Beacon Mode	Parity Mode	Throughput (bps) Half Duplex	Throughput (bps) Full Duplex
Stream	Disabled	Disabled	57.6k	N/A
Stream	Disabled	Enabled	28.8k	N/A
Acknowledge	Disabled	Disabled	38k	19k
Acknowledge	Enabled	Disabled	48k	24k
Acknowledge	Disabled	Enabled	19k	9.5k
Acknowledge	Enabled	Enabled	24k	12k

4. Configuring the AC4486

4.1 EEPROM PARAMETERS

A Host can program various parameters that are stored in EEPROM and become active after a power-on reset. **Table 7 - EEPROM Parameters**, gives the locations and descriptions of the parameters that can be read or written by a Host. Factory default values are also shown. **Do not write to any EEPROM addresses other than those listed below. Do not copy a transceiver's EEPROM data to another transceiver. Doing so may cause the transceiver to malfunction.**

Table 8 – EEPROM Parameters

Parameter	EEPROM Address	Length (Bytes)	Range	Default	Description
Product ID	00h	40			40 bytes - Product identifier string. Includes revision information for software and hardware.
Sub Hop Adjust	36h	1	0 – FFh	66h	This value should only be changed when recommended by Aerocomm.
Range Refresh	3Dh	1	1 – FFh	FFh	This byte specifies the maximum amount of time a transceiver will report In Range without having heard a beacon (equal to hop period * value). Do not set to 0h.
Stop Bit Delay	3Fh	1	0 – FFh	FFh	For systems using the RS-485 interface or Parity Mode, the serial stop bit might come too early (especially at slower interface baud rates). Stop Bit Delay controls the width of the last bit before the stop bit occurs. FFh = Disable Stop Bit Delay (12us) 00h = (256 * 1.6us) + 12us 1 – FEh = (value * 1.6us) + 12us
Channel Number	40h	1	0 – 39h	AC4486-5: 39h AC4486-500: 38h	Set 0 = 38h (Europe 500mW) – AC4486-5/500 Set 1 = 39h (Europe 5mW) – AC4486-5
Server/Client Mode	41h	1	1 – 02h	02h	01h = Server 02h = Client
Baud Rate Low	42h	1	0 – FFh	FCh	Low Byte of the interface baud rate. Default baud rate is 57,600.
Baud Rate High	43h	1	00h	00h	Always 00h

AC4486 Specifications

Parameter	EEPROM Address	Length (Bytes)	Range	Default	Description
Control 0	45h	1		10010100b (94h)	Settings are: Bit 7 – One Beacon Mode 0 = Beacon every hop 1 = Beacon once per hop cycle Bit 6 – DES Enable 0 = Disable Encryption 1 = Enable Data Encryption Bit 5 – Sync to Channel 0 = Don't Sync to Channel 1 = Sync to Channel Bit 4 – AeroComm Use Only Bit 3 – AeroComm Use Only Bit 2 – RF Mode 0 = RF Stream Mode 1 = RF Acknowledge Mode Bit 1 – RF Delivery 0 = Addressed 1 = Broadcast Bit 0 – AeroComm Use Only
Frequency Offset	46h	1	0 – FFh	01h	Protocol parameter used in conjunction with Channel Number.
Transmit Retries	4Ch	1	1 – FFh	10h	Maximum number of times a packet is sent out in Addressed Acknowledge mode.
Broadcast Attempts	4Dh	1	1 – FFh	04h	Number of times a packet is sent out in Broadcast Acknowledge mode.
API Control	56h	1		01000011b (43h)	Settings are: Bit 7 – AeroComm Use Only Bit 6 – AeroComm Use Only Bit 5 – Unicast Only 0 = Receive Addressed and Broadcast packets 1 = Only receive Addressed packets Bit 4 – Auto Destination 0 = Use Destination Address 1 = Automatically set Destination to Server Bit 3 – AeroComm Use Only Bit 2 – RTS Enable 0 = RTS Ignored 1 = Transceiver obeys RTS Bit 1 – Duplex Mode 0 = Half Duplex 1 = Full Duplex Bit 0 – Auto Config 0 = Use EEPROM values 1 = Auto Configure Values
Interface Timeout	58h	1	2 – FFh	04h	Specifies a byte gap timeout, used in conjunction with RF Packet Size, to determine when a packet is complete (0.5ms per increment).
Sync Channel	5Ah	1	0 – 36h	01h	Used to synchronize the hopping of collocated

AC4486 Specifications

					systems to minimize interference.
--	--	--	--	--	-----------------------------------

AC4486 Specifications

Parameter	EEPROM Address	Length (Bytes)	Range	Default	Description
RF Packet Size	5Bh	1	1 – FFh	46h	Used in conjunction with Interface Timeout, specifies the maximum size of an RF packet.
CTS On	5Ch	1	1 – FFh	D2h	CTS will be deasserted (High) when the transmit buffer contains at least this many characters.
CTS On Hysteresis	5Dh	1	0 – FEh	ACh	Once CTS has been deasserted, CTS will be reasserted (Low) when the transmit buffer contains this many or less characters.
Max Power	63h	1	0 – 60h	Set in production and can vary	Used to increase or decrease transmit power output.
Modem Mode	6Eh	1	E3h, FFh	FFh	E3h = Enable Modem Mode FFh = Disable Modem Mode
Parity Mode	6Fh	1	E3h, FFh	FFh	E3h = Enable Parity Mode FFh = Disable Parity Mode Note: Enabling Parity Mode cuts throughput in half and the Interface Buffer size in half.
RS-485 DE	7Fh	1	E3h, FFh	FFh	E3h = GO0 is active Low DE for control of external RS-485 hardware. FFh = Disable RS-485 DE mode
Destination ID	70h	6		FF, FF, FF, FF, FF, FFh	Specifies destination for RF packets.
System ID	76h	1	0 – FFh	01h	Similar to a network password.
MAC ID	80h	6			Factory programmed unique IEEE MAC Address.
DES Key	D0h	7	0 – FFh	0D, 1D, 2D, 3D, 4D, 5D, 6Dh	56 bit Data Encryption key

4.2 CONFIGURATION FLOW OF THE AC4486³

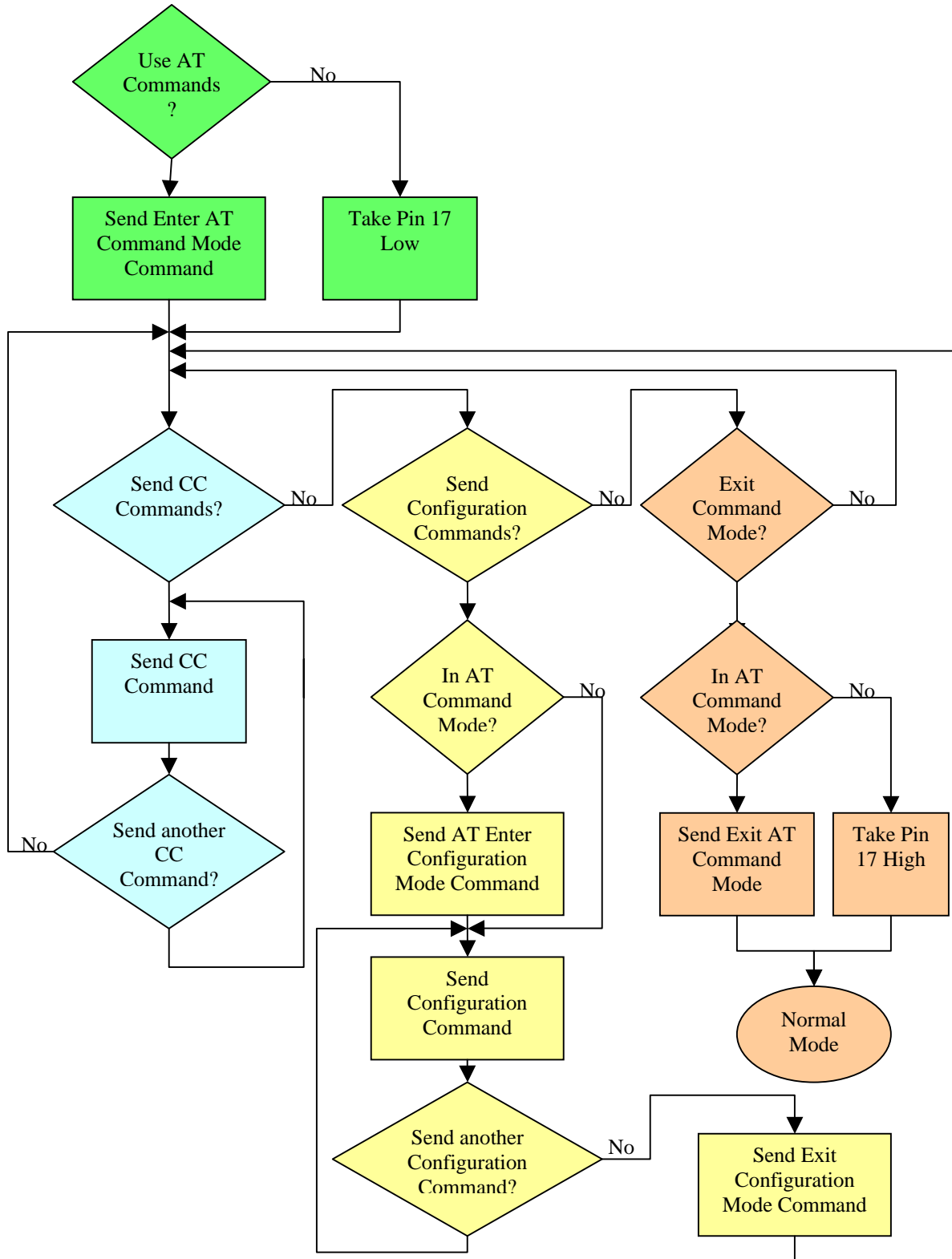

³ Any mode can be exited by resetting the transceiver; however static changes will be lost.

4.3 COMMAND QUICK REFERENCE

Below is a command reference and further information on each individual command can be found in the text following. It is strongly recommended that all the information be read on each command prior to using as some commands have caveats.

Command Name	Command (All Bytes in Hex)						Return (All Bytes in Hex)				
EEPROM Byte Read	C0h	Starting Address	Length (0 : 256 bytes)		-		C0h	Starting Address	Length	Data at those addresses	
EEPROM Byte Write	C1h	Starting Address	Length (1 – 80h)		Data bytes to be written		C1h	Starting Address	Length	Data written to last byte	
EEPROM Exit Configuration Mode	56h	-	-		-		56h	-	-	-	
AT Enter Command Mode	41h	54h	2Bh	2Bh	2Bh	0Dh	CCh	43h	4Fh	4Dh	
AT Enter Configuration Mode	CCh	65h	-		-		65h	-	-	-	
Exit AT Command Mode	CCh	41h	54h		4Fh	0Dh	CCh	44h	41h	54h	
Status Request	CCh	00h	00h		-		CCh	Firmware Version	00h: Server In Range 01h: Client In Range 02h: Server Out of Range 03h: Client Out of Range		
Change Channel without Forced Acquisition	CCh	01h	New Channel		-		CCh	New Channel	-	-	
Change Channel with Forced Acquisition	CCh	02h	New Channel		-		CCh	New Channel	-	-	
Sleep Walk Power-Down	CCh	06h	-		-		CCh	Channel	-	-	
Sleep Walk Wake-Up	CCh	07h	-		-		CCh	Channel	-	-	
Broadcast	CCh	08h	00h: Addressed 01h: Broadcast		-		CCh	00h or 01h	-	-	
Read Static Bank #1	CCh	0Ah	Address		-		CCh	Data at address	-	-	
Write Static Bank #1	CCh	0Bh	Address		Data to write		CCh	Address	Data	-	
Read Static Bank #2	CCh	0Ch	Address		-		CCh	Data at address	-	-	
Write Static Bank #2	CCh	0Dh	Address		Data to write		CCh	Address	Data	-	
Write Destination Address	CCh	10h	Byte 4 of destination's MAC	Byte 5	Byte 6		CCh	Byte 4 of destination's MAC	Byte 5	Byte 6	
Read Destination Address	CCh	11h	-		-		CCh	Byte 4 of destination's MAC	Byte 5	Byte 6	
Auto Destination	CCh	15h	Bit 0 : Auto Destination Bit 4 : Enable Auto Destination			CCh	Bit 0 : Auto Destination Bits 1 – 7: 0				
Read Digital Inputs	CCh	20h	-		-		CCh	Bit 0 : GI0 Bit 1 : GI1	-	-	

AC4486 Specifications

Command Name	Command (All Bytes in Hex)				Return (All Bytes in Hex)				
Read ADC	CCh	21h	01h: AD In 02h: Temp 03h: RSSI		-	CCh	MSB of 10 bit ADC	LSB of 10 bit ADC	-
Report Last Valid RSSI	CCh	22h	-		-	CCh	RSSI	-	-
Write Digital Outputs	CCh	23h	Bit 0 : GO0 Bit 1 : GO1		-	CCh	Bit 0 : GO0 Bit 1 : GO1	-	-
Write DAC	CCh	24h	Update Period	Duty Cycle		CCh	Update Period	Duty Cycle	-
Set Max Power	CCh	25h	New Setting		-	CCh	New Setting	-	-
Transmit Buffer Empty	CCh	30h	-		-	CCh	00h	-	-
Disable Sync-to-Channel	CCh	85h	-		-	CCh	Channel	-	-
Deep Sleep Mode	CCh	86h	-		-	CCh	Channel	-	-
Read Temperature	CCh	A4h	-		-	CCh	Temp (°C)	-	-
EEPROM Byte Read	CCh	C0h	Starting Address		Length (0 : 256 bytes)	C0h	Starting Address	Length	Data at those addresses
EEPROM Byte Write	CCh	C1h	Starting Address	Length (1 – 80h)	Data bytes to be written	C1h	Starting Address	Length	Data written to last byte
Soft Reset	CCh	FFh	-		-	-	-	-	-

4.4 EEPROM CONFIGURATION COMMANDS

The configuration commands allow the Host to modify the operation of the transceiver. If the transceiver is in Command mode (Command/Data pin (Pin 17) is pulled logic Low or the Enter AT Command mode and AT Enter Configuration mode commands have been sent to the transceiver), the transceiver will interpret incoming Host data as Command Data. The Host can then read and write parameters using the various configuration commands listed below. To exit Configuration Mode, the Host must perform a hardware or power-on reset or issue an Exit Command Mode command to the transceiver. While in Configuration Mode, the RF circuitry will be disabled.

4.4.1 EEPROM Byte Read

Upon receiving this command, a transceiver will respond with the desired data from the address requested by the Host.

Host Command:

Byte 1 = C0h
Byte 2 = Address
Byte 3 = Length (01...FFh = 1...255 bytes; 00h = 256 bytes)

Transceiver Response:

Byte 1 = C0h
Byte 2 = Address
Byte 3 = Length
Byte 4...n = Data at requested address(s)

4.4.2 EEPROM Byte Write

Upon receiving this command, a transceiver will write the data byte to the address specified but will not echo it back to the Host until the EEPROM write cycle is complete. The write can take as long as 10ms to complete. Following the write cycle, a transceiver will transmit the data byte to the Host. Multiple byte EEPROM writes are allowed up to a length of 128 bytes. An EEPROM boundary exists between addresses 7Fh and 80h. No single EEPROM write command shall write to addresses on both sides of that EEPROM boundary.

Host Command:

Byte 1 = C1h
Byte 2 = Address
Byte 3 = Length (01 – 80h)
Byte 4...n = Data to store at Address

Transceiver Response:

Byte 1 = C1h
Byte 2 = Address
Byte 3 = Length (01 – 80h)
Byte 4 = Last data byte written by this command

4.4.3 EEPROM Exit Configuration Mode Command

The OEM Host can cause the transceiver to exit Configuration Mode by issuing the Exit Configuration Mode command to the transceiver. **However, the transceiver will not reflect any of the changes programmed into the EEPROM until the transceiver is reset.**

Host Command:

Byte 1 = 56h

Transceiver Response:

Byte 1 = 56h

4.5 AC4486 AT COMMANDS

The AT Command mode implemented in AC4486 firmware version 3.2 and higher creates a virtual version of the Command/Data line. The Enter AT Command mode command asserts this virtual line Low (to signify Command mode) and the Exit AT Command mode command asserts this virtual line High (to signify Data mode). Once this line has been asserted Low, all on-the-fly CC Commands documented in the manual are supported.

When in AT Command mode, the transceiver will maintain synchronization with the network, but RF packets will not be received. However, an ambiguity of approximately 10ms exists where, if the Enter AT Command mode command has been sent to the transceiver at the same time an RF packet is being received, the RF packet could be sent to the OEM Host before the Enter AT Command mode command response is sent to the host.

4.5.1 Enter AT Command Mode

Prior to sending the Enter AT Command mode command to the transceiver, the host must ensure that the RF transmit buffer of the transceiver is empty (if the buffer is not empty, the Enter AT Command Mode command will be interpreted as packet data and transmitted out over the RF). This can be accomplished by waiting up to one second between the last transmit packet and the AT Command. The host must also ensure that the Fixed Packet Length for the transceiver is set to a minimum of six. The Enter AT Command Mode command is as follows:

Host Command:

AT+++↵

Hexadecimal Representation of the Command:

41h, 54h, 2Bh, 2Bh, 2Bh, 0Dh

Transceiver Response:

CCh COM

Hexadecimal Representation of the Command:

CCh, 43h, 4Fh, 4Dh

4.5.2 AT Enter Configuration Mode

In order to send configuration commands via AT Command mode, Configuration mode must be entered. Once in Configuration mode, standard configuration commands can be sent to the transceiver including the Exit Configuration Mode command. Upon sending the Exit Configuration mode command, the transceiver will return to AT Command mode. When in AT Command mode, Configuration mode can be entered by sending the following command to the transceiver:

Host Command:

CCh 65h

Transceiver Response:

65h

4.5.3 Exit AT Command Mode

To exit AT Command mode, the OEM host should send the following command to the transceiver:

Host Command:

CCh ATO.␣

Hexadecimal Representation of the Command:

CCh, 41h, 54h, 4Fh, 0Dh

Transceiver Response:

CCh DAT

Hexadecimal Representation of the Command:

CCh, 44h, 41h, 54h

4.6 ON-THE-FLY CONTROL COMMANDS (CC COMMAND MODE)

The AC4486 transceiver contains static memory that holds many of the parameters that control the transceiver operation. Using the “CC” command set allows many of these parameters to be changed during system operation. Because the memory these commands affect is static, when the transceiver is reset, these parameters will revert back to the settings stored in the EEPROM. **Note: Do not to modify undocumented static addresses as undesired operation may occur. All “CC” commands must be issued from the Host to the transceiver with Command/Data (Pin 17) pulled logic Low. To exit “CC” mode, simply take the Command/Data pin High.**

While in CC Command mode (using pin 17, Command/Data), the RF interface of the transceiver is still active. Therefore, it can receive packets from remote transceivers while in CC Command mode and forwards these to the OEM Host. While in CC Command mode (using AT Commands), the RF interface of the transceiver is active, but packets sent from other transceivers will not be received. The transceiver uses **Interface Timeout/Fixed Packet Length** to determine when a CC Command is complete. Therefore, there should be no delay between each character as it is sent from the OEM Host to the transceiver or the transceiver will not recognize the command and will enter Configuration Mode by default. If the OEM Host has sent a CC Command to the transceiver and a RF packet is received by the transceiver, the transceiver will send the CC Command response to the OEM Host before sending the packet. However, if a RF packet is received before the Interface Timeout expires on a CC Command, the transceiver will send the packet to the host before sending the CC Command response.

4.6.1 Status Request

The Host issues this command to request the status of the transceiver.

Host Command:

Byte 1 = CCh
Byte 2 = 00h
Byte 3 = 00h

Transceiver Response:

Byte 1 = CCh
Byte 2 = Firmware version number
Byte 3 = Data1

Where:

Data1 =
00 for Server in Normal Operation
01 for Client in Normal Operation
02 for Server in Acquisition Sync
03 for Client in Acquisition Sync

4.6.2 Change Channel without Forced Acquisition Sync

The Host issues this command to change the channel of the transceiver. The transceiver will not begin acquisition sync until its Range Refresh timer expires; therefore it is recommended that the host uses the Change Channel with Forced Acquisition Sync Command.

Host Command:

Byte 1 = CCh
Byte 2 = 01h
Byte 3 = RF Channel Number (Hexadecimal)

Transceiver Response:

Byte 1 = CCh
Byte 2 = RF Channel Number (Hexadecimal)

4.6.3 Change Channel with Forced Acquisition Sync

The Host issues this command to change the channel of the transceiver and force the transceiver to immediately begin synchronization.

Host Command:

Byte 1 = CCh
Byte 2 = 02h
Byte 3 = RF Channel Number (Hexadecimal)

Transceiver Response:

Byte 1 = CCh
Byte 2 = RF Channel Number (Hexadecimal)

4.6.4 Server/Client Command

The Host issues this command to change the mode (Server or Client) of the transceiver and can force the transceiver to actively begin synchronization. The transceiver will not begin acquisition sync until its Range Refresh timer expires; therefore it is recommended that the host uses the commands which force acquisition sync.

Host Command:

Byte 1 = CCh
Byte 2 = 03h
Byte 3 = Data1

Where:

Data1 =
00 for Server in Normal Operation
01 for Client in Normal Operation
02 for Server in Acquisition Sync
03 for Client in Acquisition Sync

Transceiver Response:

Byte 1 = CCh
Byte 2 = Software Version Number
Byte 3 = Data1

Where:

Data1 = Data1 from Host Command

4.6.5 Sync to Channel Command

The Host issues this command to change the **Sync Channel** byte and enable **Sync to Channel**.

Host Command:

Byte 1 = CCh
Byte 2 = 05h
Byte 3 = Data1

Where:

Data1 = New Sync Channel

Transceiver Response:

Byte 1 = CCh
Byte 2 = 05h
Byte 3 = Data1

Where:

Data1 = Data1 from Host Command

4.6.6 Sleep Walk Power-Down Command

After the Host issues the power-down command to the transceiver, the transceiver will de-assert the In_Range line after entering power-down. A Client transceiver in power-down will remain in sync with a Server for a minimum of 2 minutes. To maintain synchronization with the Server, this Client transceiver should re-sync to the Server at least once every 2 minutes. This re-sync is accomplished by issuing the **Power-Down Wake-Up Command** and waiting for the In Range line to go active. Once this occurs, the Client transceiver is in sync with the Server and can be put back into power-down. This command is only valid for Client transceivers.

Host Command:

Byte 1 = CCh

Byte 2 = 06h

Transceiver Response:

Byte 1 = CCh

Byte 2 = RF Channel Number

4.6.7 Sleep Walk Power-Down Wake-Up Command

The Power-Down Wake-Up Command is issued by the Host to bring the transceiver out of power-down mode.

Host Command:

Byte 1 = CCh

Byte 2 = 07h

Transceiver Response:

Byte 1 = CCh

Byte 2 = RF Channel Number

4.6.8 Broadcast Mode

The Host issues this command to change the transceiver operation between **Addressed Mode** and **Broadcast Mode**. If addressed mode is selected the transceiver will send all packets to the transceiver designated by the **Destination Address** programmed in the transceiver. If Broadcast mode is selected, the transceiver will send its packets to all transceivers on that network.

Host Command:

Byte 1 = CCh

Byte 2 = 08h

Byte 3 = 00 for addressed mode, 01 for broadcast mode

Transceiver Response:

Byte 1 = CCh

Byte 2 = 00 for addressed mode, 01 for broadcast mode

4.6.9 Read Static Bank #1 Byte

The OEM Host issues this command to the transceiver to read Static Bank #1 Bytes. Static Bank #1 is a bank of memory that holds many of the parameters that control the transceiver. Using the Read/Write Static Bank #1 command allows these parameters to be changed dynamically. Because the memory bank is static, when the transceiver is reset, these parameters will revert back to the settings stored in EEPROM. Be careful not to change Static Bank addresses unless directed to do so by AeroComm.

Host Command:

- Byte 1 = CCh
- Byte 2 = 0Ah
- Byte 3 = 00 – FFh corresponding to a valid Static Bank #1 address

Transceiver Response:

- Byte 1 = CCh
- Byte 2 = 00 – FFh corresponding to a valid Static Bank #1 address

4.6.10 Write Static Bank #1 Byte

The Host issues this command to the transceiver to write Static Bank #1 Bytes. Static Bank #1 is a bank of memory that holds many of the parameters that control the transceiver. Using the Read/Write Static Bank #1 command allows these parameters to be changed dynamically. Because the memory bank is static, when the transceiver is reset, these parameters will revert back to the settings stored in EEPROM. Be careful not to change Static Bank addresses unless directed to do so by AeroComm.

Host Command:

- Byte 1 = CCh
- Byte 2 = 0Bh
- Byte 3 = 00 – FFh corresponding to a valid Static Bank #1 address
- Byte 4 = 00 – FFh corresponding to new value for address specified by Byte 3

Transceiver Response:

- Byte 1 = CCh
- Byte 2 = 00 – FFh corresponding to a valid Static Bank #1 address
- Byte 3 = 00 – FFh corresponding to new value for address specified by Byte 2

4.6.11 Read Static Bank #2 Byte

The Host issues this command to the transceiver to read Static Bank #2 Bytes. Static Bank #2 is a bank of memory that holds many of the parameters that control the transceiver. Using the Read/Write Static Bank #2 command allows these parameters to be changed dynamically. Because the memory bank is static, when the transceiver is reset, these parameters will revert back to the settings stored in EEPROM. Be careful not to change Static Bank addresses unless directed to do so by AeroComm.

Host Command:

- Byte 1 = CCh
- Byte 2 = 0Ch
- Byte 3 = 00 – FFh corresponding to a valid Static Bank #2 address

Transceiver Response:

- Byte 1 = CCh

AC4486 Specifications

Byte 2 = 00 – FFh corresponding to a valid Static Bank #2 address

4.6.12 Write Static Bank #2 Byte

The Host issues this command to the transceiver to write Static Bank #2 Bytes. Static Bank #2 is a bank of memory that holds many of the parameters that control the transceiver. Using the Read/Write Static Bank #2 command allows these parameters to be changed dynamically. Because the memory bank is static, when the transceiver is reset, these parameters will revert back to the settings stored in EEPROM. Be careful not to change Static Bank addresses unless directed to do so by AeroComm.

Host Command:

- Byte 1 = CCh
- Byte 2 = 0Dh
- Byte 3 = 00 – FFh corresponding to a valid Static Bank #2 address
- Byte 4 = 00 – FFh corresponding to new value for address specified by Byte 3

Transceiver Response:

- Byte 1 = CCh
- Byte 2 = 00 – FFh corresponding to a valid Static Bank #2 address
- Byte 3 = 00 – FFh corresponding to new value for address specified by Byte 2

4.6.13 Write Destination Address

The Host issues this command to the transceiver to change the Destination Address. This is a **very powerful** command that provides the OEM Host with a means for ad-hoc networking. **Only the three Least Significant Bytes of the MAC Address are used for packet delivery.**

Host Command:

- Byte 1 = CCh
- Byte 2 = 10h
- Bytes 3 – 5 = 00 – FFh corresponding the three LSB's of the destination MAC Address

Transceiver Response:

- Byte 1 = CCh
- Bytes 2 – 4 = 00 – FFh corresponding the three LSB's of the destination MAC Address

4.6.14 Read Destination Address

The Host issues this command to the transceiver to read the Destination Address. This is a **very powerful** command that provides the OEM Host with a means for ad-hoc networking. **Only the three Least Significant Bytes of the MAC Address are used for packet delivery.**

Host Command:

- Byte 1 = CCh
- Byte 2 = 11h

Transceiver Response:

- Byte 1 = CCh
- Bytes 2 – 4 = 00 – FFh corresponding the three LSB's of the destination MAC Address

4.6.15 Auto Destination

The Host issues this command to change the settings for Auto Destination. When issuing this command, the Auto Destination setting will only be changed if the corresponding enable bit is set.

Host Command:

Byte 1 = CCh
Byte 2 = 15h
Byte 3 = Data1

Where:

Data1 =
Bit 0: Auto Destination
Bit 4: Enable Auto Destination Modification

Transceiver Response:

Byte 1 = CCh
Byte 2 = Data1

Where:

Data1 =
Bit 0: New Auto Destination Setting
Bits 1 – 7: 0

4.6.16 Read Digital Inputs

The Host issues this command to read the state of both digital input lines.

Host Command:

Byte 1 = CCh
Byte 2 = 20h

Transceiver Response:

Byte 1 = CCh
Byte 2 = Data1

Where:

Data1 = bit 0 – GI0, bit 1 – GI1

4.6.17 Read ADC

The Host issues this command to read any of the three 10 bit onboard A/D converters. Because the RF is still active in on-the-fly mode, the transceiver will not process the command until there is no activity on the network. **Therefore, the Read RSSI command is useful for detecting interfering sources but will not report the RSSI seen from a remote transceiver on the network.** The equations for converting these 10 bits into analog values are as follows:

$$\text{Analog Voltage} = (10 \text{ bits} / 3\text{FFh}) * 3.3\text{V}$$

$$\text{Temperature (}^\circ\text{C)} = ((\text{Analog Voltage} - 0.3) / 0.01) - 30$$

$$\text{RSSI Value (dBm)} = -105 + (0.22 * (3\text{FFh} - 10 \text{ bits}))$$

Host Command:

Byte 1 = CCh
Byte 2 = 21h
Byte 3 = Data1

Where:

Data1 = 00h – AD In, 01h – Temperature (if equipped), 02h – RSSI

Transceiver Response:

Byte 1 = CCh
Byte 2 = Data1
Byte 3 = Data2

Where:

Data1 = MSB of requested 10 bit ADC value
Data2 = LSB of requested 10 bit ADC value

4.6.18 Report Last Valid RSSI

As RSSI values are only valid when the local transceiver is receiving a RF packet from a remote transceiver, instantaneous RSSI can be very tricky to use. Therefore, the transceiver stores the most recent valid RSSI value. The Host issues this command to request that value. Note: This value will default to FFh on a Client and 00h on a Server if no valid RSSI measurement has been made since power-up. The Host issues this command to read the last valid RSSI:

Host Command:

Byte 1 = CCh

Byte 2 = 22h

Transceiver Response:

Byte 1 = CCh

Byte 2 = Data1

Where:

Data1 = Most significant 8 bits of last valid RSSI reading.

Signal Strength (dBm)	Last Good RSSI Value (hex)
3 to 7	20
-9 to 2	10
-15 to -10	0
-45 to -16	10
-57 to -46	20
-62 to -58	40
-64 to -63	60
-65 to -67	80
-72 to -68	C0
-88 to -72	E0
-95 to -89	F0

Note: Notice the trend between -9dBm and 7dBm does not follow the curve. This is because the RSSI becomes saturated at signal levels above -40dBm.

4.6.19 Write Digital Outputs

The Host issues this command to write both digital output lines to particular states.

Host Command:

Byte 1 = CCh
Byte 2 = 23h
Byte 3 = Data1

Where:

Data1 = bit 0 – GO0, bit 1 – GO1

Transceiver Response:

Byte 1 = CCh
Byte 2 = Data1

Where:

Data1 = Data1 from Host command

4.6.20 Write DAC

The Host issues this command to write DA Out to a particular voltage. NOTE: DA Out is an unbuffered, high impedance output and **must be buffered** by the OEM Host when used. The transceiver uses a PWM (Pulse Width Modulator) to generate the analog voltage. The theory behind PWM is that a binary pulse is generated with a fixed duty cycle and rate. As such, this pin toggles between High and Low. This signal is filtered via an onboard R-C circuit and an analog voltage is generated. Duty Cycle specifies the ratio of time in one cycle that the pulse spends High proportionate to the amount of time it spends Low. So, with a duty cycle of 50% (80h), the pulse is High 50% of the time and Low 50% of the time; therefore the analog voltage would be half of 3.3V or 1.15V. A broad filter has been implemented on the transceiver and there is no advantage to using a slower update period. Generally, a faster update period is preferred.

Host Command:

Byte 1 = CCh
Byte 2 = 24h
Byte 3 = Data1
Byte 4 = Data2

Where:

Data1 = Update Period where: $T_{\text{Update}} = (255 * (\text{Data1} + 1)) / 14.7256^{+06}$
Data2 = Duty Cycle where: $V_{\text{out}} = (\text{Data2} / \text{FFh}) * 3.3\text{V}$

Transceiver Response:

Byte 1 = CCh
Byte 2 = Data1
Byte 3 = Data2

Where:

Data1 = Data1 from Host Command
Data2 = Data2 from Host Command

4.6.21 Set Max Power

The Host Issues this command to limit the maximum transmit power emitted by the transceiver. This can be useful to minimize current consumption and satisfy certain regulatory requirements.

Host Command:

Byte 1 = CCh
Byte 2 = 25h
Byte 3 = Data1

Where:

Data1 = New Max Power

Transceiver Response:

Byte 1 = CCh
Byte 2 = Data1

Where:

Data1 = Data1 from Host Command

4.6.22 Transmit Buffer Empty

The Host issues this command to determine when the RF Transmit buffer is empty. The Host will not receive the transceiver response until that time.

Host Command:

Byte 1 = CCh
Byte 2 = 30h

Transceiver Response:

Byte 1 = CCh
Byte 2 = 00h

4.6.23 Disable Sync to Channel

The Host issues this command to disable Sync to Channel mode.

Host Command:

Byte 1 = CCh
Byte 2 = 85h

Transceiver Response:

Byte 1 = CCh
Byte 2 = RF Channel Number

4.6.24 Deep Sleep Mode

The Host issues this command to put the transceiver into Deep Sleep mode. Once in Deep Sleep, the transceiver disables all RF communications and will not respond to any further commands until being reset or power cycled. This command is valid for both Servers and Clients.

Host Command:

Byte 1 = CCh

Byte 2 = 86h

Transceiver Response:

Byte 1 = CCh

Byte 2 = RF Channel Number

4.6.25 Read Temperature

The Host issues this command to read the onboard temperature sensor. The transceiver reports the temperature in °C where 0 – 80h corresponds to 0 – 80°C and where D8 – 0h corresponds to -40 – 0°C.

Host Command:

Byte 1 = CCh

Byte 2 = A4h

Transceiver Response:

Byte 1 = CCh

Byte 2 = Data1

Where:

Data1 = D8 – 80h

4.6.26 EEPROM Byte Read

Upon receiving this command, a transceiver will respond with the desired data from the address requested by the Host.

Host Command:

Byte 1 = CCh

Byte 2 = C0h

Byte 3 = Address

Byte 4 = Length (01...FFh = 1...255 bytes; 00h = 256 bytes)

Transceiver Response:

Byte 1 = CCh

Byte 2 = Address

Byte 3 = Length

Byte 4...n = Data at requested address(s)

4.6.27 EEPROM Byte Write

Upon receiving this command, a transceiver will write the data byte to the address specified but will not echo it back to the Host until the EEPROM write cycle is complete. The write can take as long as 10ms to complete. Following the write cycle, a transceiver will transmit the data byte to the Host. Multiple byte EEPROM writes are allowed up to a length of 128 bytes. An EEPROM boundary exists between addresses 7Fh and 80h. No single EEPROM write command shall write to addresses on both sides of that EEPROM boundary.

Host Command:

- Byte 1 = CCh
- Byte 2 = C1h
- Byte 3 = Address
- Byte 4 = Length (01 – 80h)
- Byte 5...n = Data to store at Address

Transceiver Response:

- Byte 1 = CCh
- Byte 2 = Address
- Byte 3 = Length (01 – 80h)
- Byte 4 = Last data byte written by this command

4.6.28 Reset Command

The Host issues this command to perform a soft reset of the transceiver. Any transceiver settings modified by CC Commands will be overwritten by values stored in the EEPROM.

Host Command:

- Byte 1 = CCh
- Byte 2 = FFh

Transceiver Response:

- There is no response from the transceiver

5. Theory of Operation

5.1 HARDWARE INTERFACE

Below is a description of all hardware pins used to control the AC4486.

5.1.1 GIn (Generic Inputs 0 and 1) (pins 4 and 14 respectively) and GOn (Generic Outputs 0 and 1) (pins 1 and 9 respectively)

Both GIn pins serve as generic input pins. Both GOn pins serve as generic output pins. Reading and writing of these pins can be performed using CC Commands (details can be found in the *On-the-Fly Control Command Reference*). These pins alternately serve as control pins when Modem Mode is enabled in the EEPROM.

5.1.2 TXD (Transmit Data) and RXD (Receive Data) (pins 2 and 3 respectively)

Serial TTL

The AC4486 accepts 3.3 or 5VDC TTL level asynchronous serial data (the 500mW/ 1000mW transceiver ONLY accepts 3.3V level signals) on the RXD pin and interprets that data as either Command Data or Transmit Data. Data is sent from the transceiver, at 3.3V levels, to the OEM Host via the TXD pin.

RS-485

When equipped with an onboard RS-485 interface chip, TXD and RXD become the half duplex RS-485 pins. In this mode, the transceiver will be in listen mode except when it has data to send to the OEM host. TXD is the noninverted representation of the data (RS485A) and RXD is a mirror image of TXD (RS485B). The transceiver will still use RTS (if enabled) in this mode.

5.1.3 Hop Frame (pin 6)

Hop Frame transitions logic Low at the start of a hop and transitions logic High at the completion of a hop. The OEM Host is not required to monitor Hop Frame. The AC4486 is a single frequency transceiver, though it still generates a Hop Frame signal every time it transmits a timing beacon.

5.1.4 CTS Handshaking (pin 7)

The AC4486 has an interface buffer size of 256 bytes. If the buffer fills up and more bytes are sent to the transceiver before the buffer can be emptied, data loss will occur. The transceiver prevents this loss by asserting CTS High as the buffer fills up and taking CTS Low as the buffer is emptied. **CTS On** in conjunction with **CTS On Hysteresis** control the operation of CTS. CTS On specifies the amount of bytes that must be in the buffer for CTS to be disabled (High). Even while CTS is disabled, the OEM Host can still send data to the transceiver, but it should do so carefully. Once CTS is disabled, it will remain disabled until the buffer is reduced to the size specified by CTS On Hysteresis.

5.1.5 RTS Handshaking (pin 8)

With **RTS Mode** disabled, the transceiver will send any received packet to the OEM Host as soon as the packet is received. However, some OEM Hosts are not able to accept data from the transceiver all of the time. With RTS Mode Enabled, the OEM Host can keep the transceiver from sending it a packet by disabling RTS (logic High). Once RTS is enabled (logic Low), the transceiver can send packets to the OEM Host as they are received. **Note: Leaving RTS disabled for too long can cause data loss once the transceiver's 256 byte receive buffer fills up.**

5.1.6 9600 Baud (pin 12)

9600_BAUD – When pulled logic Low before applying power or resetting, the transceiver's serial interface is forced to a 9600, 8-N-1 (8 data bits, No parity, 1 stop bit) rate. To exit, the transceiver must be reset or power-cycled with 9600_Baud logic High. This pin is used to recover transceivers from unknown baud rates only. It should not be used in normal operation. Instead the transceiver Interface Baud Rate should be programmed to 9600 baud if that rate is desired for normal operation.

5.1.7 RSSI (pin 13)

Instantaneous RSSI

Received Signal Strength Indicator is used by the Host as an indication of instantaneous signal strength at the receiver. The Host must calibrate RSSI without a RF signal being presented to the receiver. Calibration is accomplished by following the steps listed below.

1. **Power up only one Client (no Server) transceiver in the coverage area.**
2. **Measure the RSSI signal to obtain the minimum value with no other signal present.**
3. **Power up a Server. Make sure the two transceivers separated by approximately ten feet and measure the Client's peak RSSI, once the Client reports In Range, to obtain a maximum value at full signal strength.**

Validated RSSI

As RSSI values are only valid when the local transceiver is receiving a RF packet from a remote transceiver, instantaneous RSSI can be very tricky to use. Therefore, the transceiver stores the most recent valid RSSI value. The Host issues the *Report Last Good RSSI* command to request that value (details can be found in the *On-the-Fly Control Command Reference*). Validated RSSI is not available at the RSSI pin. The following equation approximates the RSSI curve:

$$\text{Signal Strength (dBm)} = (-46.9 * V_{\text{RSSI}}) - 53.9$$

Figure 1 – RSSI Voltage vs. Received Signal Strength

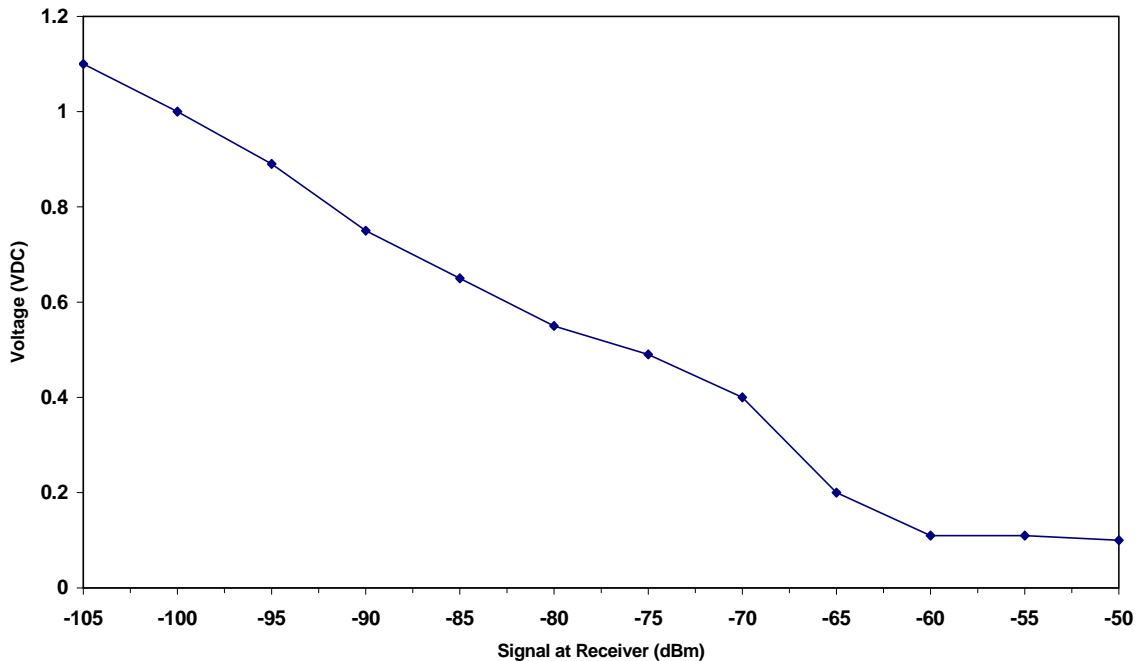

5.1.8 UP_Reset (pin 15)

UP_Reset provides a direct connection to the reset pin on the AC4486 microprocessor and is used to force a soft reset. For a valid reset, reset must be High for a minimum of 10ms.

5.1.9 Command/Data (pin 17)

When logic High, the transceiver interprets incoming Host data as transmit data to be sent to other transceivers and their Hosts. When logic Low, the transceiver interprets Host data as command data (see section 4).

5.1.10 AD In and DA Out (pins 18 and 19 respectively)

AD In and DA Out can be used as a cost savings to replace Analog-to-Digital and Digital-to-Analog converter hardware. Reading and writing of these two pins locally can be performed using commands found in the *On-the-Fly Control Command Reference*. Note: DA Out is an unbuffered, high impedance output and **must be buffered** by the OEM Host when used.

5.1.11 In Range (pin 20)

The IN_RANGE pin at the connector will be driven logic Low when a Client is in range of a Server on the same **RF Channel** and **System ID**. If a Client cannot hear a Server for the amount of time specified by **Range Refresh**, it will drive the IN_RANGE pin logic High and enter a search mode looking for a Server. As soon as it detects a Server, the IN_RANGE pin will be driven logic Low. A Server Host can determine which Clients are in range by the Server's Host software polling a Client's Host. IN_RANGE will always be Low on the Server.

5.2 SOFTWARE PARAMETERS

Following is a description of all software parameters used to control the AC4486.

5.2.1 RF Architecture (Unicast/Broadcast)

The Server controls the system timing by sending out regular beacons (transparent to the transceiver Host) which contain system timing information. This timing information synchronizes the Client transceivers to the Server.

Each network should consist of only one Server. There should never be two Servers on the same **RF Channel Number** in the same coverage area as the interference between the two Servers will severely hinder RF communications.

The AC4486 runs a Peer-to-Peer type architecture where all transceivers, whether Servers or Clients, can communicate with all other transceivers. To prohibit transceivers from receiving broadcast packets, **Unicast Only** can be enabled.

5.2.2 RF Mode

All transceivers located on the same network must use the same RF Mode.

RF Delivery Overview

All packets are sent out over the RF as either addressed or broadcast packets. Addressed packets are only received by the transceiver specified by **Destination Address**. If addressed packets are desired, the Destination Address should be programmed with the **MAC ID** of the destination transceiver. To simplify EEPROM programming, **Auto Destination** can be enabled in Clients which allows the Client to automatically set its Destination Address to the address of the Server. Broadcast packets are sent out to every eligible transceiver on the network. If broadcast packets are desired, **RF Delivery** should be set to Broadcast.

Acknowledge Mode

In Addressed Acknowledge Mode, the RF packet is sent out to the receiver designated by the **Destination Address**. **Transmit Retries** is used to increase the odds of successful delivery to the intended receiver. Transparent to the OEM Host, the sending transceiver will send the RF packet to the intended receiver. If the receiver receives the packet free of errors, it will tell the sender. If the sender does not receive this acknowledge, it will assume the packet was never received and retry the packet. This will go on until the packet is successfully received or the transmitter exhausts all of its retries. The received packet will only be sent to the OEM Host if and when it is received free of errors.

In Broadcast Acknowledge Mode, the RF packet is broadcast out to all eligible receivers on the network. **Broadcast Attempts** is used to increase the odds of successful delivery to the intended receiver(s). Transparent to the OEM Host, the sending transceiver will send the RF packet to the intended receiver. If the receiver detects a packet error, it will throw out the packet. This will go on until the packet is successfully received or the transmitter exhausts all of its attempts. Once the receiver successfully receives the packet it will send the packet to the OEM Host. It will throw out any duplicates caused by further Broadcast Attempts. The received packet will only be sent to the OEM Host if it is received free of errors.

Stream Mode

In Broadcast Stream mode, the RF packet is broadcast out to all eligible receivers on the network. In Addressed Stream Mode, the RF packet is sent out to the receiver designated by the **Destination Address**. The sending transceiver will send each RF packet out once. There are no retries on the packet. Whether or not the packet contains errors, the receiver(s) will send the packet to the OEM Host. In fact, if only part of the packet is able to be received, the transceiver will still send the partial packet to the OEM Host. **Note: Stream Mode is incompatible with Full Duplex Mode.**

5.2.3 Sub Hop Adjust

Sub Hop Adjust is an AC4486 protocol parameter and should only be modified at the recommendation of Aerocomm.

5.2.4 Duplex Mode

In Half Duplex mode, the AC4486 will send a packet out over the RF when it can. This can cause packets sent at the same time by a Server and a Client to collide with each other over the RF. To prevent this, Full Duplex Mode can be enabled. This mode restricts Clients to transmitting on odd numbered frequency “bins” and the Server to transmitting on even frequency bins. Though the RF hardware is still technically half duplex, it makes the transceiver seem full duplex. This can cause overall throughputs to be cut in half. **Note: All transceivers on the same network must have the same setting for Full Duplex. Full Duplex mode is incompatible with Stream RF mode.**

5.2.5 Interface Timeout/RF Packet Size

Interface Timeout, in conjunction with **RF Packet Size**, determines when a buffer of data will be sent out over the RF as a complete RF packet based on whichever condition occurs first.

Interface Timeout – Interface Timeout specifies a maximum byte gap between consecutive bytes. When that byte gap is exceeded, the bytes in the transmit buffer are sent out over the RF as a complete packet. Interface timeout is adjustable in 0.5ms increments and has a tolerance of ± 0.5 ms. Therefore, the Interface Timeout should be set to a minimum of 2. The default value for Interface Timeout is 4 or 2ms.

RF Packet Size – When the amount of bytes in the transceiver transmit buffer equals RF Packet Size, those bytes are sent out as a complete RF packet. Every packet the transceiver sends over the RF contains extra header bytes not counted in the RF Packet Size. Therefore, it is much more efficient to send a few large packets than to send many short packets. However, if RF Packet size is set too large and Acknowledge Mode is enabled, the transceiver will not be able to send any packets because Acknowledge Mode requires the entire RF packet to be sent in the same hop whereas Stream Mode packets can span multiple hops.

5.2.6 Serial Interface Baud Rate

This two-byte value determines the baud rate used for communicating over the serial interface to a transceiver. **Table 8 - Baud Rate/Timeout** lists values for some common baud rates. Baud rates below 1200 baud are not supported. For a baud rate to be valid, the calculated baud rate must be within $\pm 3\%$ of the OEM Host baud rate. **If the 9600 BAUD pin (Pin 12) is pulled logic Low at reset, the baud rate will be forced to 9,600.** For Baud Rate values other than those shown in **Table 5 - Baud Rate**, the following equation can be used:

$$\text{BAUD} = 100h - (14.7456E^{+06} / (64 * \text{desired baud rate}))$$

BaudH= Always 0

BaudL = Low 8 bits of BAUD (base16)

Table 9 – Baud Rate/Interface Timeout

Baud Rate	BaudL (42h)	BaudH (43h)	Minimum Interface Timeout (58h)	Stop Bit Delay (3Fh)
115,200	FEh	00h	02h	FFh
57,600 ⁴	FCh	00h	02h	03h
38,400	FAh	00h	02h	08h
28,800	F8h	00h	02h	0Eh
19,200	F4h	00h	03h	19h
14,400	F0h	00h	04h	23h
9,600	E8h	00h	05h	39h
4800	D0h	00h	09h	7Ah
2400	A0h	00h	11h	FCh
1200	40h	00h	21h	00h ⁵

5.2.7 Network Topology

RF Channel Number – RF Channel Number selects the operational frequency band of the transceiver. The AC4486 provides two channels of operation based on output power and transmit duty cycle. **The AC4486 does not restrict the duty cycle or power output and the OEM is responsible for ensuring that these requirements are met.** This information is provided in the chart below:

⁴ 57,600 is the default baud rate.

⁵ 00h will yield a stop bit of 421uS. The stop bit at 1200 baud should be 833us.

Table 10 – US and International RF Channel Number Settings

Channel Set	RF Channel Number Range (40h)	Frequency Details and Regulatory Requirements	Countries	Frequency Offset (46h)
0 (AC4486-5, AC4486-500)	38h	869.4 – 869.65MHz (Single frequency. Up to 500mW EIRP at 10% maximum transmit vs. receive duty cycle)	Europe	0
1 (AC4486-5)	39h	869.7 – 870MHz (Single frequency. Up to 5mW EIRP with no duty cycle requirement)	Europe	0

Frequency Offset – Frequency Offset is an AC4486 protocol parameter used in conjunction with RF Channel Number.

System ID – System ID is similar to a password character or network number and makes network eavesdropping more difficult. A receiving transceiver will not go in range of or communicate with another transceiver on a different System ID.

DES (Data Encryption Standard) – Encryption is the process of encoding an information bit stream to secure the data content. The DES algorithm is a common, simple and well-established encryption routine. An encryption key of 56 bits is used to encrypt the packet. The receiver must use the exact same key to decrypt the packet; otherwise garbled data will be produced.

The 7 byte (56 bits) Encryption/Decryption Key is located in EEPROM Bytes D0 – D6. It is highly recommended that this Key be changed from the default. In addition to setting the value of the Encryption/Decryption Key in the EEPROM, the OEM can change this key in the transceiver static memory during system operation by using the Write Static Bank #2 Byte command to modify addresses D0 – D6h.

5.2.8 Auto Config

The AC4486 has several variables that control its RF performance and vary by **RF Mode** and **RF Architecture**. Enabling Auto Config will bypass the value for these variables stored in EEPROM and use predetermined values for the given mode. Below is a list containing all of the variables affected by Auto Config and their respective predetermined values (values are all in hexadecimal format). When Auto Config is disabled, these values must be programmed in the transceiver EEPROM for the corresponding mode of operation.

Table 11 – Auto Config Parameters

Parameter (those not named are undocumented protocol parameters)	EEPROM Address	Default	Stream Mode	Acknowledge Mode	
				One Beacon Mode Disabled	One Beacon Mode Enabled
Sub Hop Adjust	36	66	A0	A0	A0
	47	0E	0E	0E	0E
	48	90	90	90	90
	4E	09	08	09	09
	53	80	N/A ⁶	80	80
	54	07	07	07	07
RF Packet Size	5B	46	90	50	68
CTS On	5C	D2	C0	DC	DC
CTS On Hysteresis	5D	AC	BE	B0	B0
	5E	23	10	23	23
	5F	08	08	08	08

5.2.9 One Beacon Mode

The beacon, which is sent by the Server and contains system timing information, takes approximately 1ms to send. Enabling One Beacon mode causes the beacon to only be sent once per complete hop cycle. Because the AC4486 is single frequency, the beacon is not required for the Client to locate the Server. Therefore, One Beacon mode is enabled by default to minimize the amount of time spent sending beacons.

Table 12 – One Beacon Mode Settings

Address	One Beacon Enabled	One Beacon Disabled
45h	Set bit 7	Clear bit 7
3Dh	FFh	18h

Range Refresh – The Server sends out timing beacons at regular intervals to maintain Client synchronization. Upon hearing a beacon, a Client will be in range of the Server and will assert its IN_RANGE pin Low. Each time the Client hears a Server beacon, it resets the Range Refresh timer. If the timer ever expires the Client will be out of range, will take the IN_RANGE pin High and will enter acquisition mode trying to find the Server again. Therefore, Range Refresh specifies the maximum amount of time a Client can go without hearing a Server beacon. This variable is particularly useful when operating on fringe coverage areas. The Range Refresh timer is equal to 320ms * the value of Range Refresh. **Note: Range Refresh should not be set to 0h.**

⁶ N/A: This parameter is not affected by Auto Config and the EEPROM value is used instead.

5.2.10 Max Power

Max Power provides a means for controlling the RF transmit output power of the AC4486. Output power and current consumption can vary by as much as $\pm 10\%$ per transceiver for a particular Max Power setting. Contact Aerocomm for assistance in adjusting Max Power. The following graphs show current consumption versus output power. Transmit power can be represented in dBm (decibels per meter) and mW (milliwatts). The equations for converting between the two are shown below:

$$\text{Power (dBm)} = 10 \log_{10} \text{Power (mW)}$$

$$\text{Power (mW)} = 10^{(\text{Power (dBm)} / 10)}$$

Table 13 – Max Power Settings for AC4486-5 Transmitter

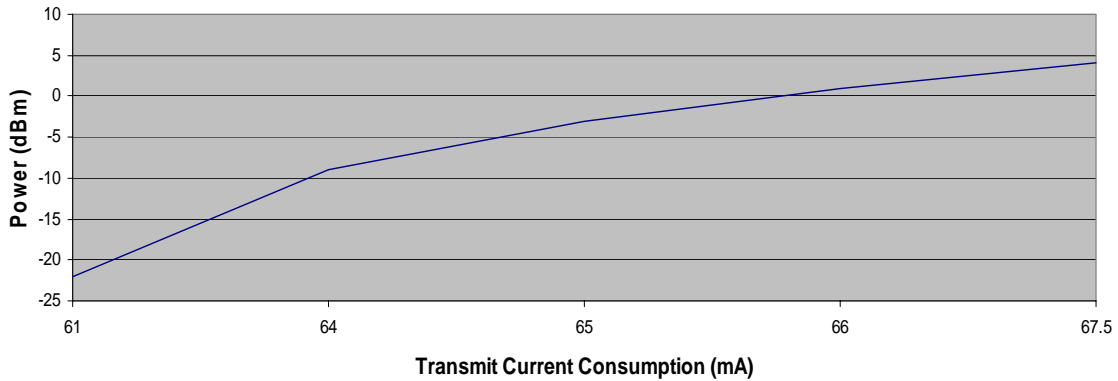

Interface Options

Modem Mode – Full modem handshaking is supported by the transceivers when enabled in EEPROM. Modem Mode is incompatible with RS-485 DE mode. Because Command/Data performs an alternate function when this mode is enabled, CC on-the-fly commands cannot be used and Configuration Mode is entered by forcing 9600 baud through the 9600_BAUD pin. Therefore, modem mode, though enabled in EEPROM, will be ignored when 9600 baud is forced. Both modem interfaces are shown below.

Table 14 – Transceiver Interface to DCE (Server Transceiver)

When Interfacing the AC4486 to a DCE (Data Communications Equipment):				
DCE Pin Number	DCE Pin Name	Direction with Respect to Transceiver	AC4486 Pin Name	AC4486 Pin Number
1	DCD	In	GI1	14
2	RXD	In	RXD	3
3	TXD	Out	TXD	2
4	DTR	Out	GO0	1
5	GND			5
6	DSR	In	Command/Data	17
7	RTS	Out	CTS	7
8	CTS	In	RTS	8
9	RI	In	GI0	4

Table 15 – Transceiver Interface to DTE (Client Transceiver)

When Interfacing the AC4486 to a DTE (Data Terminal Equipment):				
DTE Pin Number	DTE Pin Name	Direction with Respect to Transceiver	AC4486 Pin Name	AC4486 Pin Number
1	DCD	Out	GO0	1
2	RXD	Out	TXD	2
3	TXD	In	RXD	3
4	DTR	In	GI0	4
5	GND			5
6	DSR	Out	Hop Frame	6
7	RTS	In	RTS	8
8	CTS	Out	CTS	7
9	RI	Out	GO1	9

RS-485 DE Control – When enabled in EEPROM, the transceiver will use the GO0 pin to control the DE pin on external RS-485 circuitry. If enabled, when the transceiver has data to send to the host, it will assert GO0 Low, send the data to the host, and take GO0 High.

6. Dimensions

Critical parameters are as follows:

Interface Connector – 20 pin OEM interface connector (Samtec TMM-110-01-L-D-SM, mates with Samtec SMM-110-02-S-D)

MMCX Jack – Antenna connector (Telegartner P/N J01341C0081) mates with any manufacturer's MMCX plug

Figure 2 - AC4486 (with MMCX Connector) Mechanical

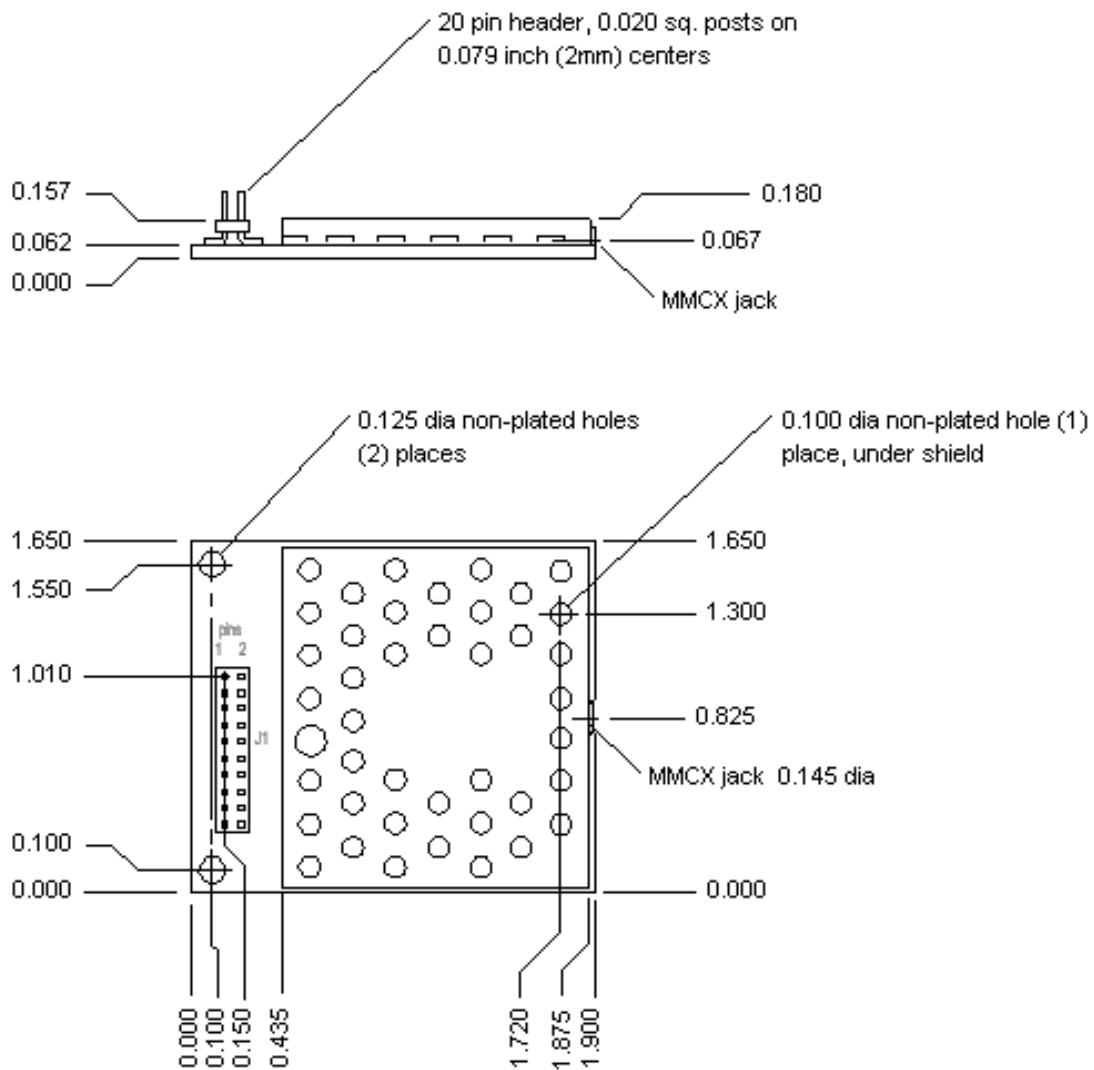
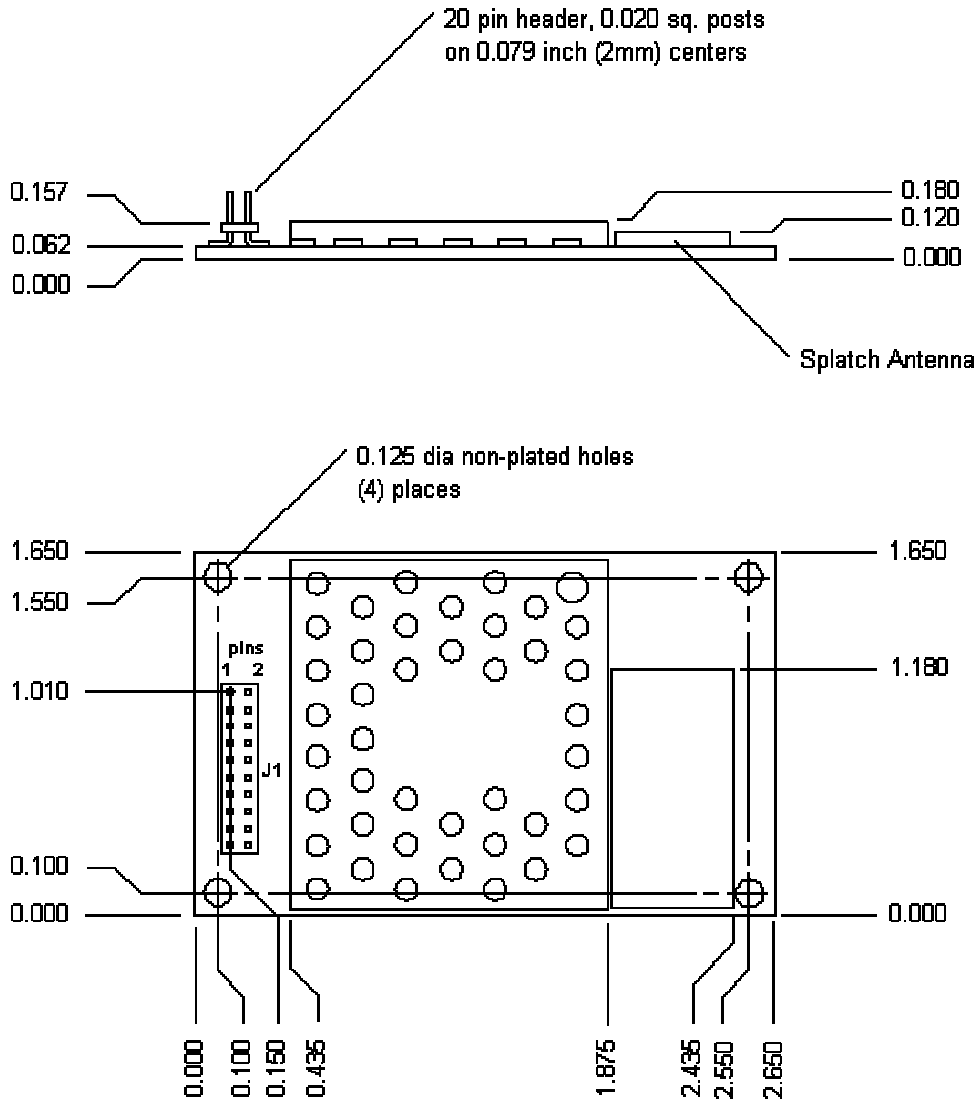

Figure 3 - AC4486 (with Integral Splat Antenna) Mechanical



7. Ordering Information

7.1 PRODUCT PART NUMBER TREE

AC4486-XXXX-XXX

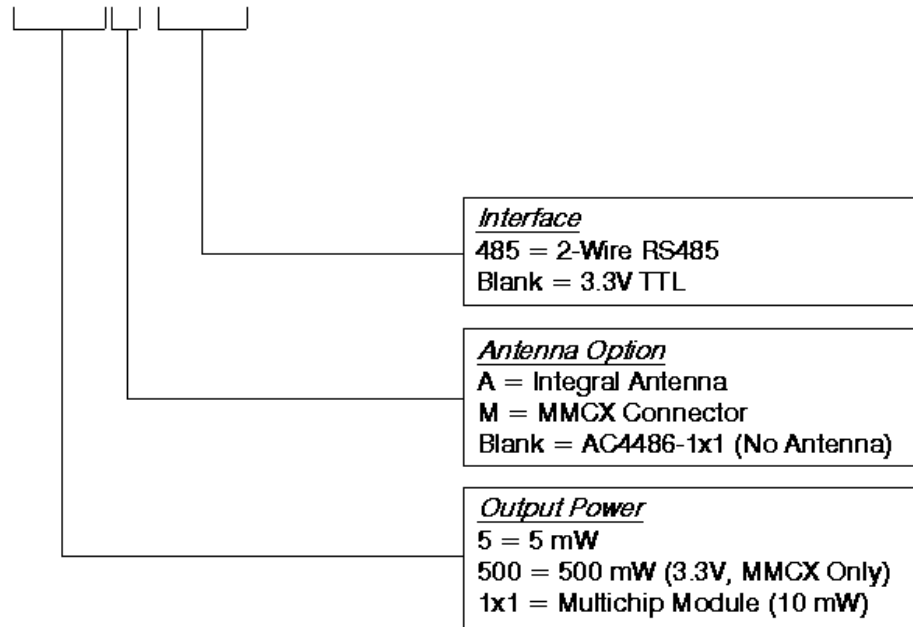

7.2 DEVELOPER KIT PART NUMBERS

All the above part numbers can be ordered as a development kit by prefacing the part number with "SDK-". As an example, part number AC4486-5M can be ordered as a development kit using the following part number: SDK-AC4486-5M.

All Developer Kits include (2) transceivers, (2) Serial Adapter Boards, (2) 6VDC unregulated power supplies, (2) Serial cables, (2) USB cables, (2) S467FL-6-RMM-915S dipole antennas with 6" pigtail and MMCX connector, configuration/testing software, and integration engineering support.

8. Agency Compliance Information

Agency compliance is a very important requirement for any product deployment. AeroComm obtains modular approval for its products so the OEM only has to meet a few requirements to be eligible to use that approval.

Table 16 – CE Approval Status

Part Number	EUR/EN
AC4486-5	Approved
AC4486-500	Pending

8.1 APPROVED ANTENNA LIST

The following antennas are approved for operation with the AC4486 as identified. **The OEM is free to choose another vendor's antenna of equal or lesser gain and similar type as an antenna appearing in the table and still maintain compliance.**

Table 17 – AC4486 Approved Antenna List

AeroComm Part Number	Manufacturer Part Number	Manufacturer	Type	Gain (dBi)	AC4486-5A	AC4486-5M	AC4486-500M
0600-00020	S467FL-6-RMM-868S	Nearson	¼ Wave Dipole	2		M	M
	ANT-868-SP	Linx Tech	Microstrip	-1	M		

8.2 OEM EQUIPMENT LABELING REQUIREMENTS

Following are the requirements for labeling equipment:

1. If the CE marking is reduced or enlarged, the proportions given in the following graduated drawing must be respected.
2. The CE marking must have a height of at least 5 mm except where this is not possible on account of the nature of the apparatus.
3. The CE marking must be affixed to the product or to its data plate. Additionally it must be affixed to the packaging, if any, and to the accompanying documents.
4. The CE marking must be affixed visibly, legibly and indelibly.
5. The exclamation point must be included with the CE mark (as shown below) to alert the user to the fact that there are restrictions placed on usage in certain countries. It must have the same height as the CE mark.

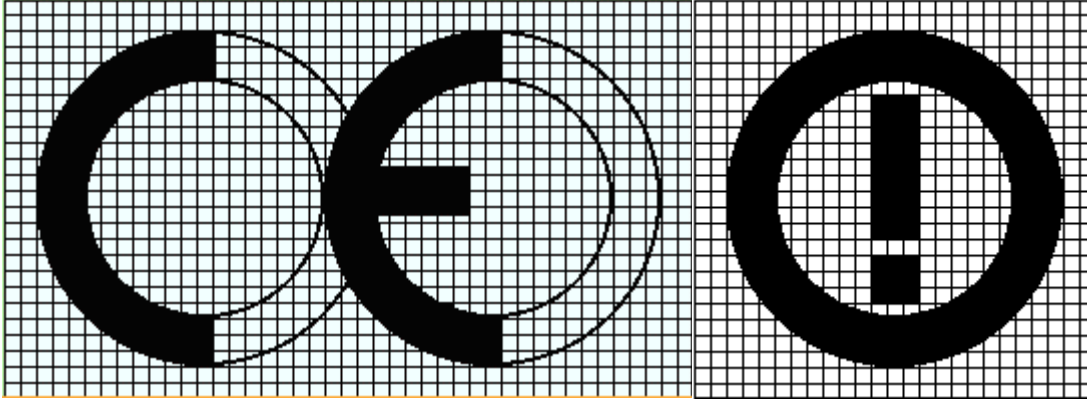

8.3 COUNTRY RESTRICTIONS

The exclamation point included with the CE mark denotes that the equipment has restrictions in certain countries. Following is a list of countries having restrictions on the AC4486 and a description of those restrictions. The OEM is responsible for insuring that these restrictions are met.

Table 18 – Restrictions

AC4486 Channel	Country	Restriction	Reason/Remarks
38h (Band I)	All Countries (unless otherwise noted)	Maximum ERP of 500mW and maximum transmit duty cycle of 10% (amortized over one hour)	
	Bulgaria	Not Implemented	
	Finland	Audio and voice not allowed	
	Germany	Audio and voice not allowed	
	Italy	Max 25mW ERP	Military Applications
	Slovak Republic	Not Implemented	Military
39h (Band K)	All Countries (unless otherwise noted)	Maximum ERP of 5mW	
	Bulgaria	Not Implemented	
	Croatia	Channel spacing 25kHz or 50kHz	
	Finland	Audio and voice not allowed	
	Germany	Audio and voice not allowed	
	Slovak Republic	Not Implemented	Military Services

8.4 COUNTRY NOTIFICATION

The OEM is responsible for notifying ANY country of the intent to ship product to that country containing the AC4486 four weeks prior to shipping.

8.5 DECLARATIONS OF CONFORMITY

The following documents corresponding to the product and band of use must appear in the OEM user's manual if applicable.



DECLARATION OF CONFORMITY

APPLICATION OF COUNCIL DIRECTIVE(S): R&TTE Directive 1999/5/EC
EMC Directive 89/336/EEC

MANUFACTURER'S NAME: Aerocomm Inc.
10981 Eicher Drive
Lenexa, Kansas
USA, 66219

**EUROPEAN REPRESENTATIVE'S
NAME/ADDRESS:** Wireless World AG
Kirchstrasse 28
CH-8574 Lengwil-Oberhofen

PRODUCT UNDER TEST: 868 k Band Transceiver
MODEL NO.: AC4486-5M
RF OUTPUT POWER: 5 mW EIRP
FREQUENCY RANGE: 869.6-870 MHz

TEST LABORATORIES: NCEE (A2LA accredited test facilities)
4740 Discovery Dr.
Lincoln, NE 68521

Senton GmbH
Äußere Frühlingsstraße
D-94315 Straubing

STANDARD(S) TO WHICH CONFORMITY IS DECLARED:

Protection requirements concerning electromagnetic compatibility pursuant to Article 3.1.b
Standards applied: **ETSI EN 301 489-3 v1.4.1 (2002-08)**
Reference REN/ERM-EMC-230-3

Measures for the efficient use of the radio frequency spectrum pursuant to Article 3.2
Standards applied: **ETS 300 220-3 v1.1.1 (2000-09)**
Reference REN/ERM-RP08-0403-3

I, the undersigned, hereby declare that the equipment as tested is representative within manufacturing tolerance to production units.

Manufacturer

Signature

John Eckart

Full Name

VP Sales

Position

10981 Eicher Drive, Lenexa, KS

Place

November 8, 2004

Date

Legal Representative in Europe

Signature

Michael Schröttle

Full Name

President

Position

CH-8574 Lengwil-Oberhofen

Place

November 08, 2004

Date

10981 Eicher Drive – Lenexa, KS 66219 – 800.492.2320 – Fax 913.492.1243
www.aerocomm.com



DECLARATION OF CONFORMITY

APPLICATION OF COUNCIL DIRECTIVE(S): R&TTE Directive 1999/5/EC
EMC Directive 89/336/EEC

MANUFACTURER'S NAME: Aerocomm Inc.
10981 Eicher Drive
Lenexa, Kansas
USA, 66219

EUROPEAN REPRESENTATIVE'S
NAME/ADDRESS: Wireless World AG
Kirchstrasse 28
CH-8574 Lengwil-Oberhofen

PRODUCT UNDER TEST: 868 k Band Transceiver
MODEL NO.: AC4486-5A
RF OUTPUT POWER: 5 mW EIRP
FREQUENCY RANGE: 869.7-870 MHz

TEST LABORATORIES: NCEE (A2LA accredited test facilities)
4740 Discovery Dr.
Lincoln, NE 68521

Senton GmbH
Äußere Frühlingsstraße
D-94315 Straubing

STANDARD(S) TO WHICH CONFORMITY IS DECLARED:

Protection requirements concerning electromagnetic compatibility pursuant to Article 3.1.b
Standards applied: **ETSI EN 301 489-3 v1.4.1 (2002-08)**
Reference REN/ERM-EMC-230-3

Measures for the efficient use of the radio frequency spectrum pursuant to Article 3.2
Standards applied: **ETS 300 220-3 v1.1.1 (2000-09)**
Reference REN/ERM-RP08-0403-3

I, the undersigned, hereby declare that the equipment as tested is representative within manufacturing tolerance to production units.

Manufacturer

Signature

John Eckart
Full Name

VP Sales
Position

10981 Eicher Drive, Lenexa, KS
Place

November 8, 2004
Date

Legal Representative in Europe

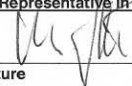
Signature

Michael Schröttle
Full Name

President
Position

CH-8574 Lengwil-Oberhofen
Place

November 08, 2004
Date

10981 Eicher Drive – Lenexa, KS 66219 – 800.492.2320 – Fax 913.492.1243
www.aerocomm.com



DECLARATION OF CONFORMITY

APPLICATION OF COUNCIL DIRECTIVE(S): R&TTE Directive 1999/5/EC
EMC Directive 89/336/EEC

MANUFACTURER'S NAME: Aerocomm Inc.
10981 Eicher Drive
Lenexa, Kansas
USA, 66219

EUROPEAN REPRESENTATIVE'S
NAME/ADDRESS: Wireless World AG
Kirchstrasse 28
CH-8574 Lengwil-Oberhofen

PRODUCT UNDER TEST: 868 i Band Transceiver
MODEL NO.: AC4486-5M
RF OUTPUT POWER: 5 mW EIRP (in the 500 mW Band)
FREQUENCY RANGE: 869.4-869.65 MHz

TEST LABORATORIES: Senton GmbH
Äußere Frühlingsstraße
D-94315 Straubing

STANDARD(S) TO WHICH CONFORMITY IS DECLARED:

Protection requirements concerning electromagnetic compatibility pursuant to Article 3.1.b
Standards applied: **ETSI EN 301 489-3 v1.4.1 (2002-08)**
Reference REN/ERM-EMC-230-3

Measures for the efficient use of the radio frequency spectrum pursuant to Article 3.2
Standards applied: **ETS 300 220-3 v1.1.1 (2000-09)**
Reference REN/ERM-RP08-0403-3

I, the undersigned, hereby declare that the equipment as tested is representative within manufacturing tolerance to production units.

Manufacturer

Signature
John Eckart
Full Name
VP Sales
Position
10981 Eicher Drive, Lenexa, KS
Place
November 8, 2004
Date

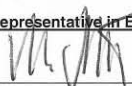
Legal Representative in Europe

Signature
Michael Schröttle
Full Name
President
Position
CH-8574 Lengwil-Oberhofen
Place
November 08, 2004
Date

10981 Eicher Drive – Lenexa, KS 66219 – 800.492.2320 – Fax 913.492.1243
www.aerocomm.com



DECLARATION OF CONFORMITY

APPLICATION OF COUNCIL DIRECTIVE(S): R&TTE Directive 1999/5/EC
EMC Directive 89/336/EEC

MANUFACTURER'S NAME: Aerocomm Inc.
10981 Eicher Drive
Lenexa, Kansas
USA, 66219

EUROPEAN REPRESENTATIVE'S
NAME/ADDRESS: Wireless World AG
Kirchstrasse 28
CH-8574 Lengwil-Oberhofen

PRODUCT UNDER TEST: 868 i Band Transceiver
MODEL NO.: AC4486-5A
RF OUTPUT POWER: 5 mW EIRP (in the 500 mW Band)
FREQUENCY RANGE: 869.4-869.65 MHz

TEST LABORATORIES: Senton GmbH
Äußere Frühlingsstraße
D-94315 Straubing

STANDARD(S) TO WHICH CONFORMITY IS DECLARED:

Protection requirements concerning electromagnetic compatibility pursuant to Article 3.1.b
Standards applied: ETSI EN 301 489-3 v1.4.1 (2002-08)
Reference REN/ERM-EMC-230-3

Measures for the efficient use of the radio frequency spectrum pursuant to Article 3.2
Standards applied: ETS 300 220-3 v1.1.1 (2000-09)
Reference REN/ERM-RP08-0403-3

I, the undersigned, hereby declare that the equipment as tested is representative within manufacturing tolerance to production units.

Manufacturer

Signature
John Eckart
Full Name
VP Sales
Position
10981 Eicher Drive, Lenexa, KS
Place
November 8, 2004
Date

Legal Representative in Europe

Signature
Michael Schröttle
Full Name
President
Position
CH-8574 Lengwil-Oberhofen
Place
November 08, 2004
Date