



LTE ANTÉNA

Anténa GSM/UMTS/LTE,
7-9 dBi, SMA(m), 3 m /RG195

AO-ALTE-MG9S-F

Společnost SECTRON nabízí široký výběr GSM/UMTS/LTE antén, které se liší ve tvarech, velikostech zisku a metodách uchycení. SECTRON garantuje kompatibilitu mezi anténou a všemi anténními redukciemi, se stejným konektorem, které jsou vyrobeny společností SECTRON.



VÝHODY

- Nízké VSWR
- Vysoký Zisk

Technologie	GSM/UMTS/LTE
Frekvenční pásma	700/800/900/1700/1800/1900/2100/2500/2600/2700 MHz
Šířka pásma	-
Zisk	7-9 dBi
VSWR	<2.0:1
Impedance	50 Ohm
Směrnost	Všesměrová
Vyzařovací úhel	H 360° V 30°
Polarizace	Lineární
Maximální vstupní Výkon	10 W
Napájecí napětí	-
Rozměry	Prut: \varnothing 10 x 315 mm / Základna: \varnothing 75 x 31 mm
Hmotnost	204 \pm 10 g
Provozní teplota	-30 to +80 °C
Provedení	Externí
Metoda uchycení	Magnetická
Typ kabelu	RG195 / U
*Standardní délka kabelu	3 m
Typ konektoru	SMA(m)

VÝKRES

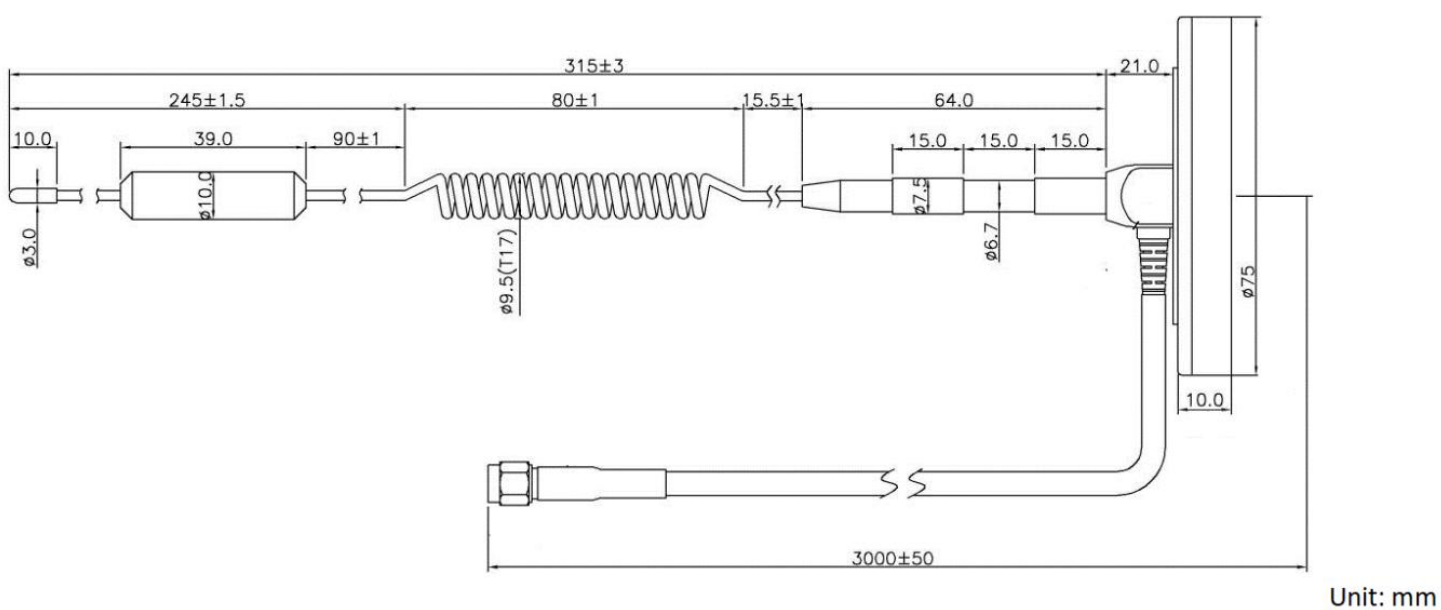

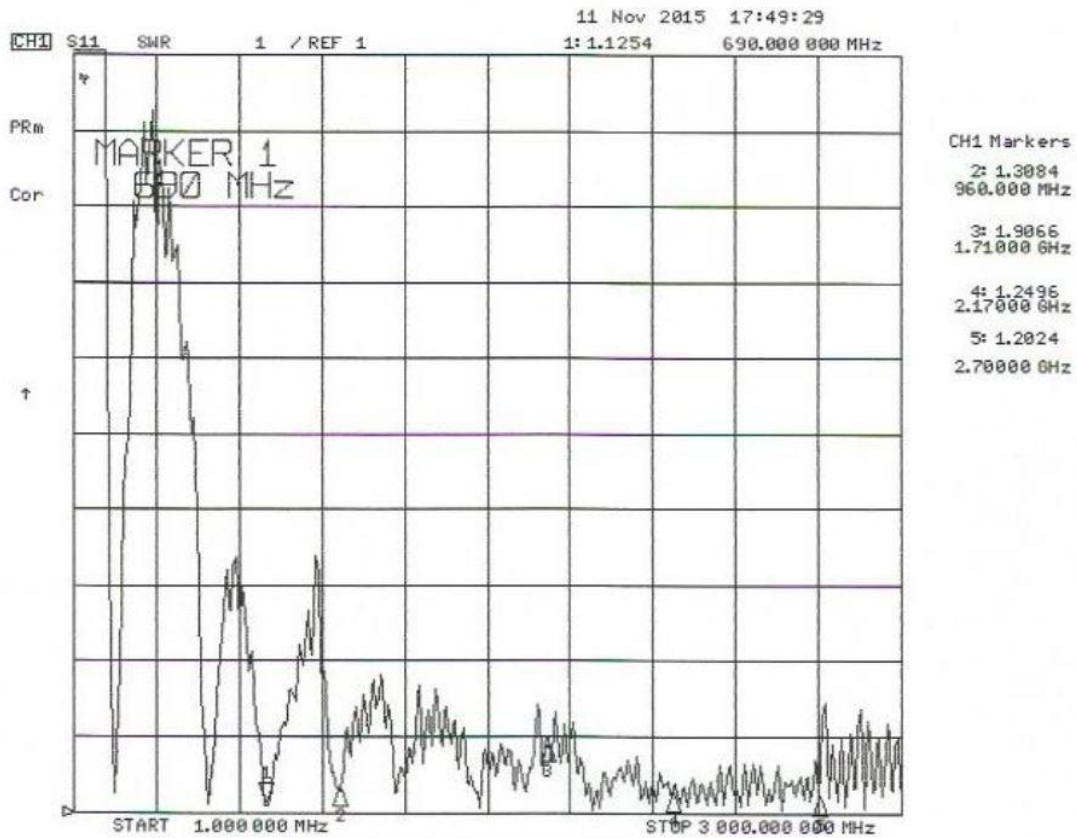
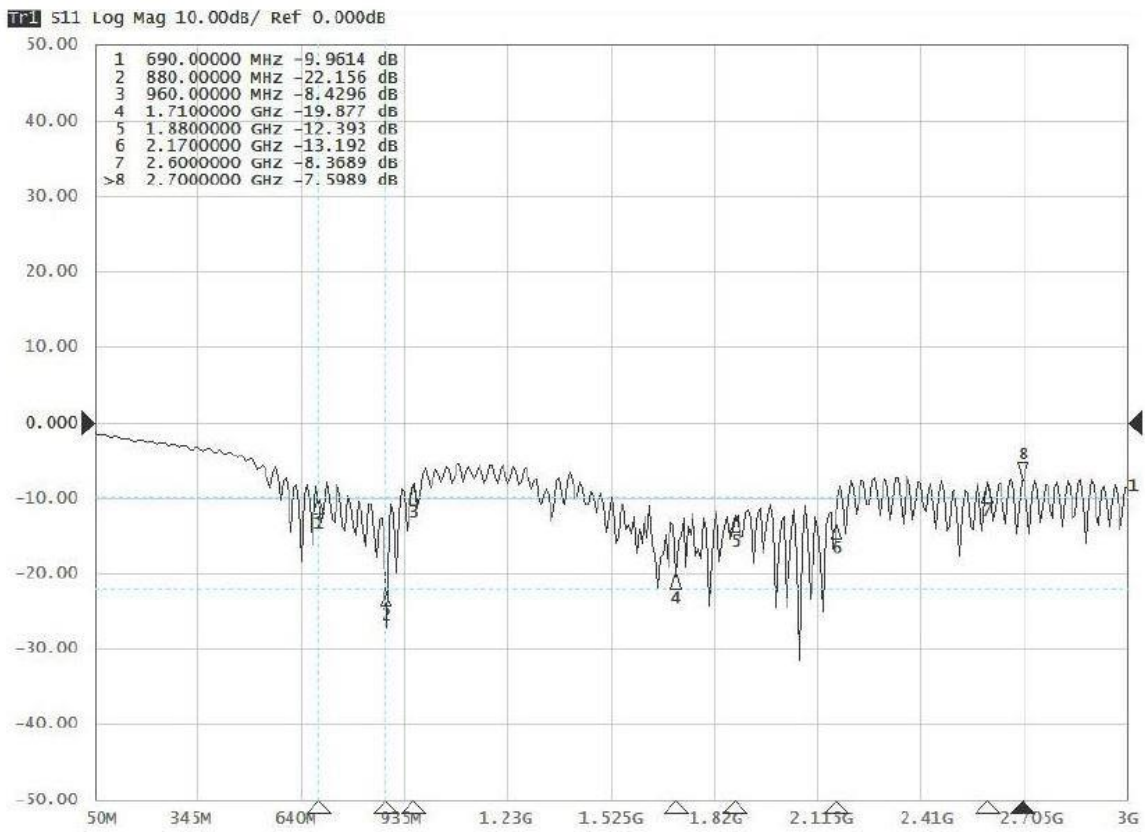

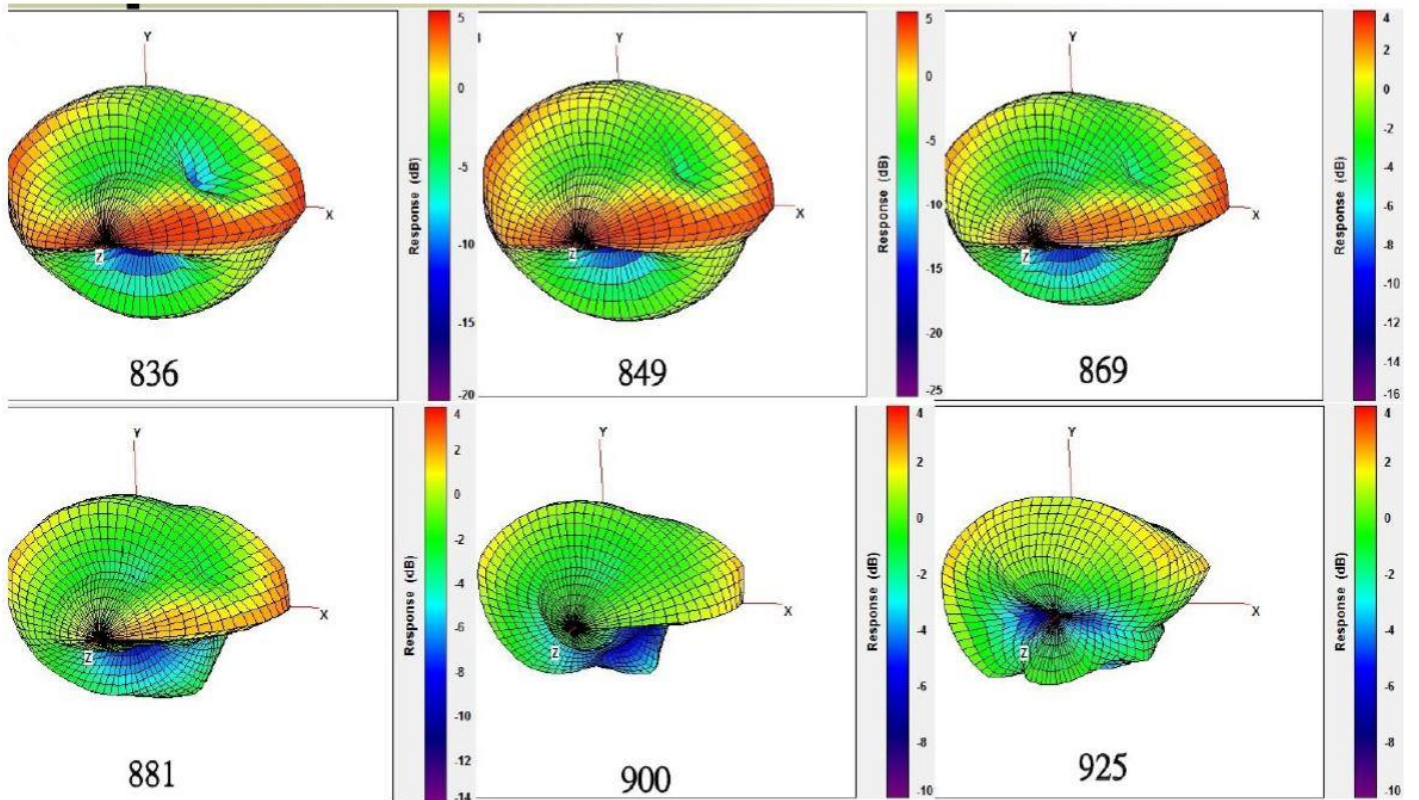
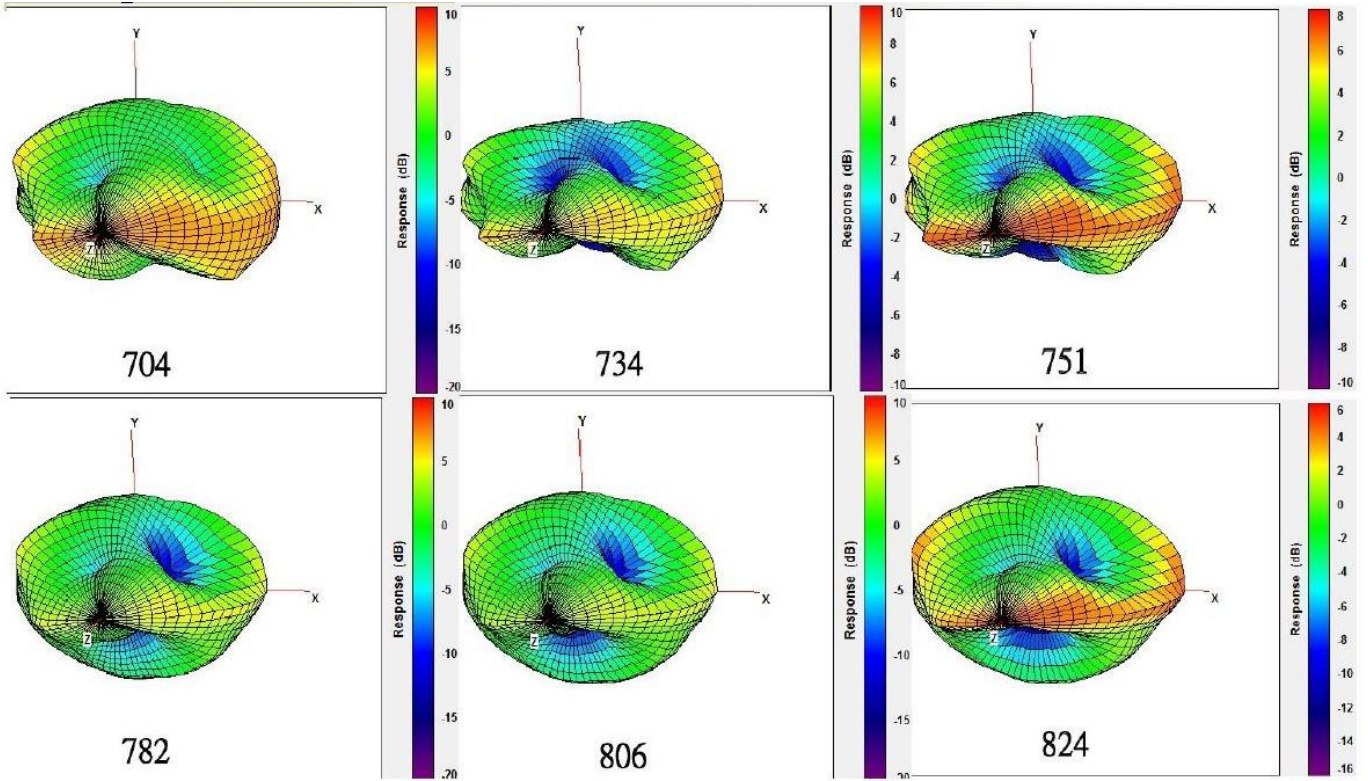

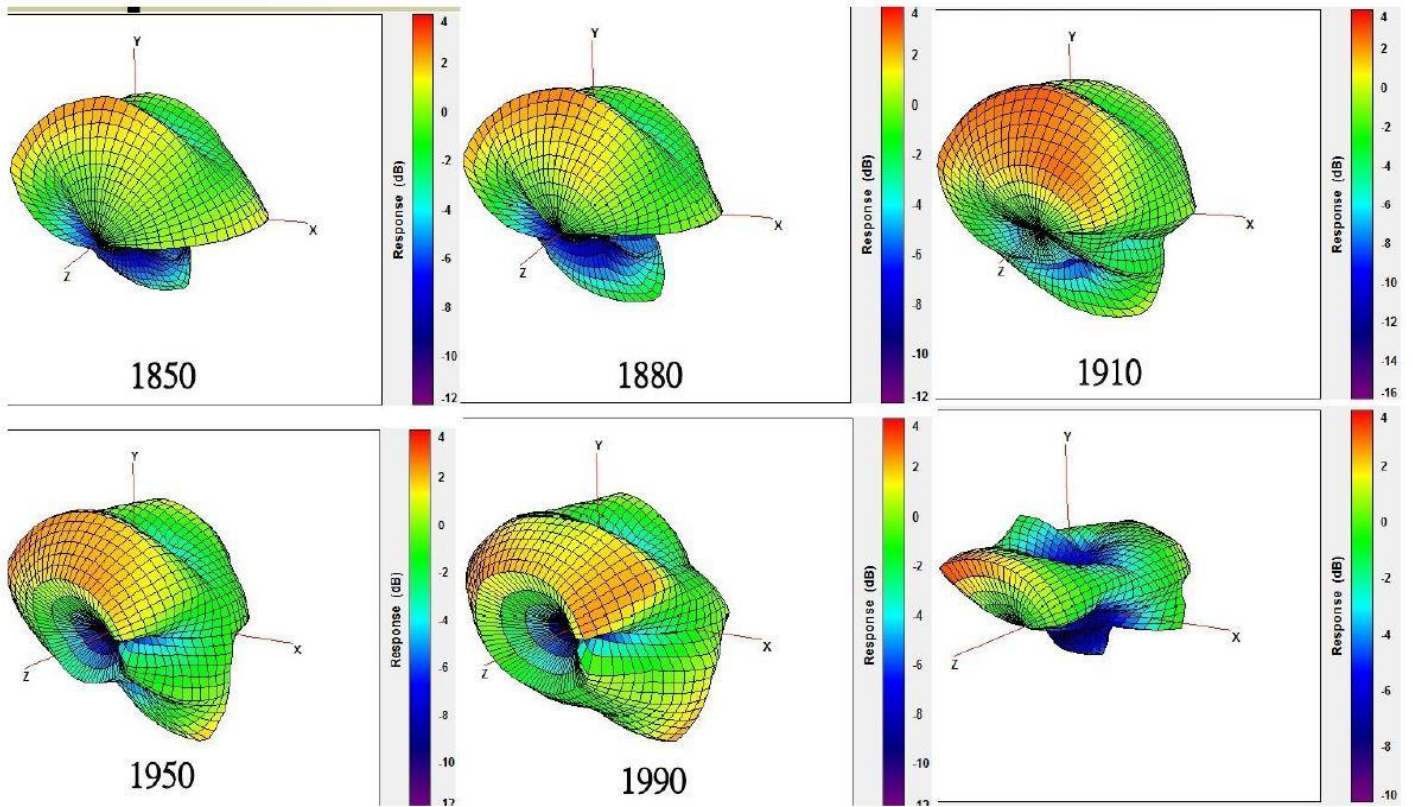
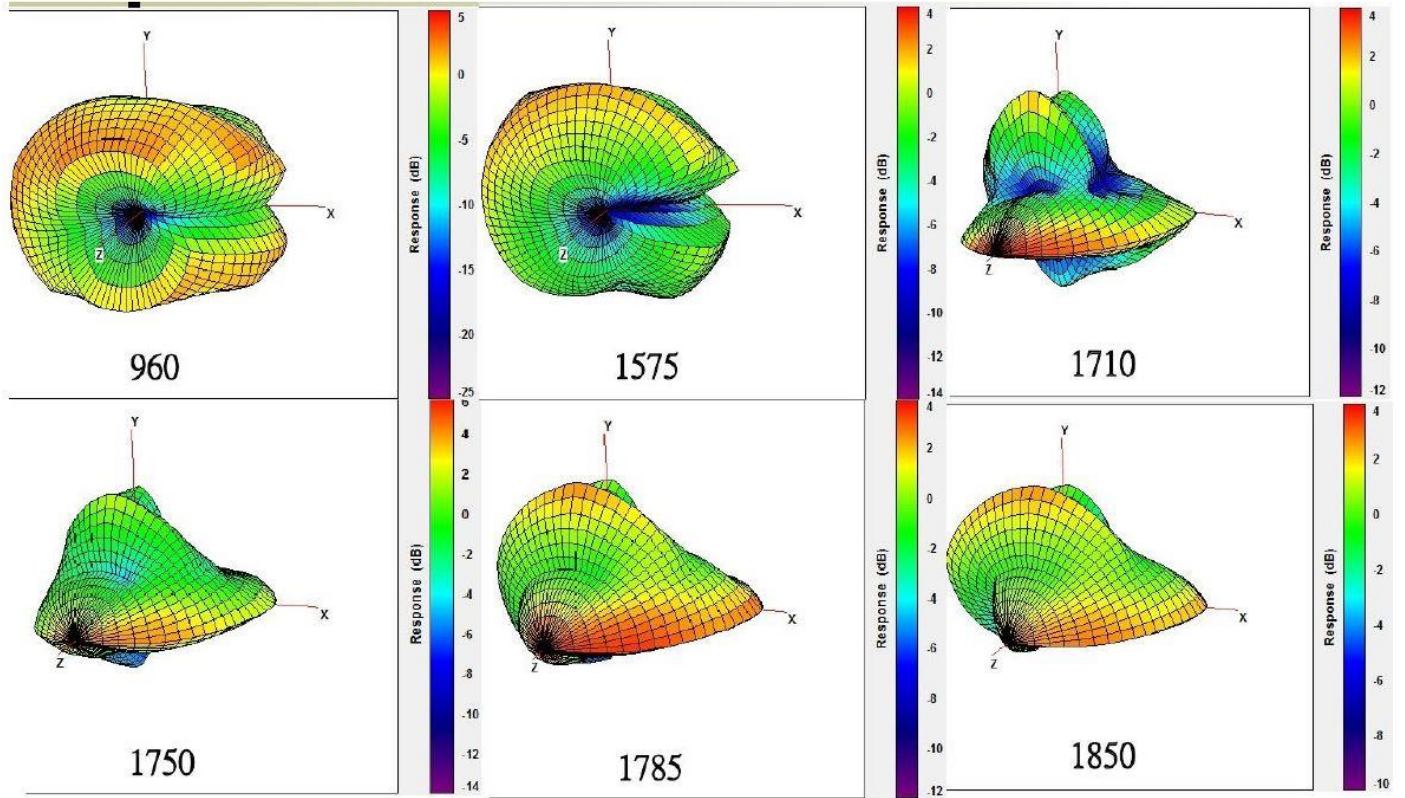

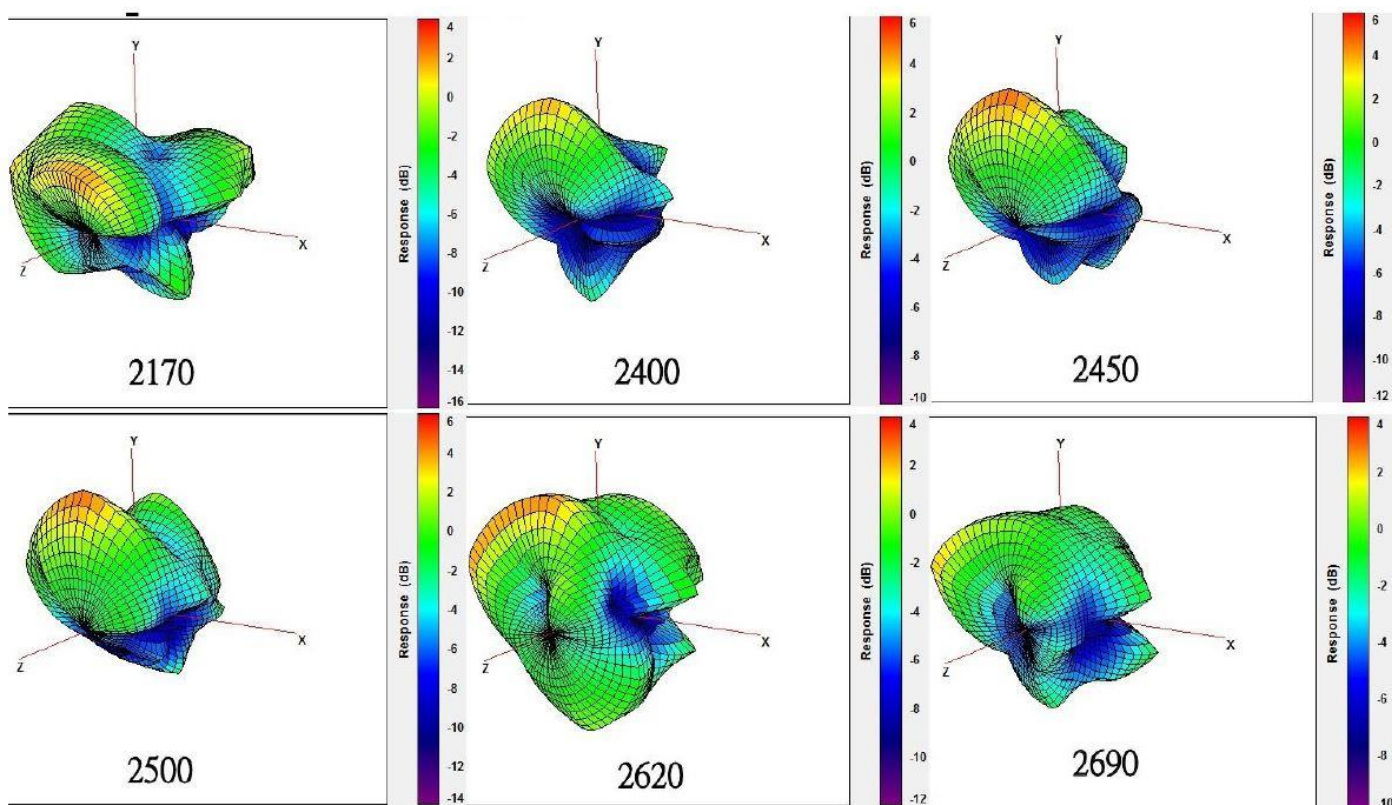

Frequency (MHz)	704	710	716	734	740	746	751	756	777	782	787	791	806	815	821
Average Gain (dB)	2.95	3.25	3.26	3.28	3.05	2.90	2.73	2.51	1.24	0.96	0.59	0.40	0.83	0.65	0.55
Peak EIRP (dBm)	7.15	7.29	7.44	8.03	7.91	7.79	7.61	7.34	5.82	5.54	5.19	5.03	5.44	5.13	4.92
Frequency (MHz)	824	830	832	836	845	847	849	860	862	869	875	880	881	890	894
Average Gain (dB)	0.52	0.41	0.40	0.34	0.12	0.02	-0.09	-0.57	-0.66	-0.94	-1.13	-1.25	-1.31	-1.36	-1.34
Peak EIRP (dBm)	4.79	4.49	4.44	4.39	4.22	4.17	4.08	3.69	3.63	3.30	3.01	2.74	2.67	2.40	2.40
Frequency (MHz)	900	915	925	940	960	1427.9	1447.9	1462.9	1475.9	1495.9	1510.9	1574.7	1575.4	1576.4	1602
Average Gain (dB)	-1.21	-0.83	-0.62	-0.40	-0.43	-2.13	-2.36	-2.61	-2.79	-2.67	-2.42	-0.79	-0.78	-0.77	-0.36
Peak EIRP (dBm)	2.47	2.52	2.48	2.93	2.86	1.89	1.92	1.75	1.39	1.48	1.81	2.17	2.17	2.21	3.31
Frequency (MHz)	1710	1750	1755	1785	1805	1840	1850	1880	1882	1910	1920	1930	1950	1962	1980
Average Gain (dB)	-2.74	-2.51	-2.45	-1.85	-1.67	-1.63	-1.62	-1.45	-1.42	-1.00	-0.81	-0.68	-0.47	-0.37	-0.28
Peak EIRP (dBm)	3.90	4.12	4.15	3.54	2.97	2.75	2.70	2.78	2.74	2.90	2.88	2.83	2.99	3.09	2.86
Frequency (MHz)	1990	2110	2132	2140	2155	2170	2400	2450	2500	2535	2570	2620	2655	2690	
Average Gain (dB)	-0.24	-2.04	-2.32	-2.40	-2.42	-2.28	-1.51	-1.91	-2.33	-1.87	-1.45	-1.45	-1.84	-2.26	
Peak EIRP (dBm)	2.71	3.92	3.82	3.67	3.48	3.22	4.56	5.23	5.13	4.51	3.54	2.87	2.67	2.75	

DOSTUPNÉ VARIANTY

*Rozdílné délky kabelů a typy konektorů jsou dostupné na vyžádání.

KONTAKT