



GSM ANTENNA

Antenna GSM Adhesive FLAT,
2.5 dBi, FME(f), RG174/5m

AO-AGSM-SATF2

SECTRON company offers wide a portfolio of GSM antennas with various versions differing in shape, level of gain and manner of attachment. SECTRON guarantees a compatible connection between an antenna and all antenna adaptors produced by SECTRON.



BENEFITS

- Low VSWR
- Easy installation

Technology	GSM
Frequency bands	900/1800 MHz
Bandwidth	-
Gain	2.5 dBi
VSWR	<1.8:1
Impedance	50 Ohm
Directivity	Omnidirectional
Beam angle	H 360° V 30°
Polarization	Linear
Maximum input power	10 W
Power voltage	-
Dimensions	123 x 61 x 4.5 mm
Weight	79,82 g
Operating temperature	-30 to +90 °C
Execution	External
Method of attachment	Adhesive
Cable type	RG174/U
The cable length	5 m
Connector type	FME(f)

DRAWING

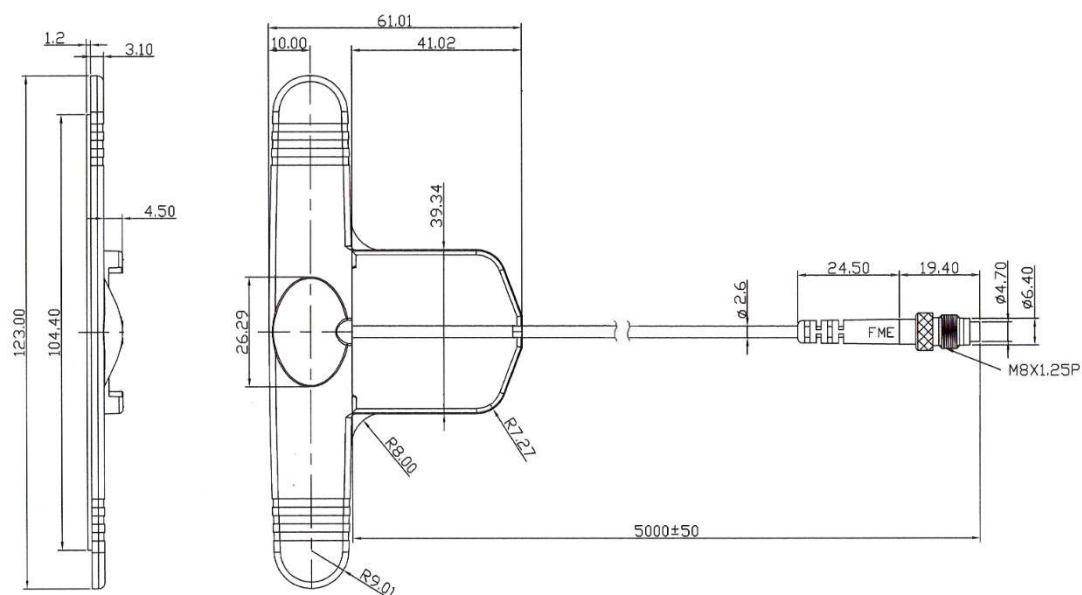

CONTACTS