



GSM ANTENNA

Anténa GSM Adhesive 25,
2.5 dBi, FME(f), RG174/3m

AO-AGSM-SA1F

SECTRON company offers a wide portfolio of GSM antennas with various versions differing in shape, level of gain and manner of attachment. SECTRON guarantees compatible connection between an antenna and all antenna adaptors produced by SECTRON.



BENEFITS

- Low VSWR
- Optimized high frequency gain
- Flexible

Technology	GSM
Frequency bands	900, 1800, 1900, 2100 MHz
Bandwidth	-
Gain	2.5 dBi
VSWR	<2.0:1
Impedance	50 Ohm
Directivity	Omnidirectional
Beam angle	H 360° V 30°
Polarization	Vertical
Maximum input power	10 W
Power voltage	-
Dimensions	129.5 x 22.8 x 6.7 mm
Weight	52.78 g
Operating temperature	--40°C to +80°C
Execution	External
Method of attachment	Adhesive
Cable type	RG174/U
The cable length	3 m
Connector type	FME(f)

DRAWING

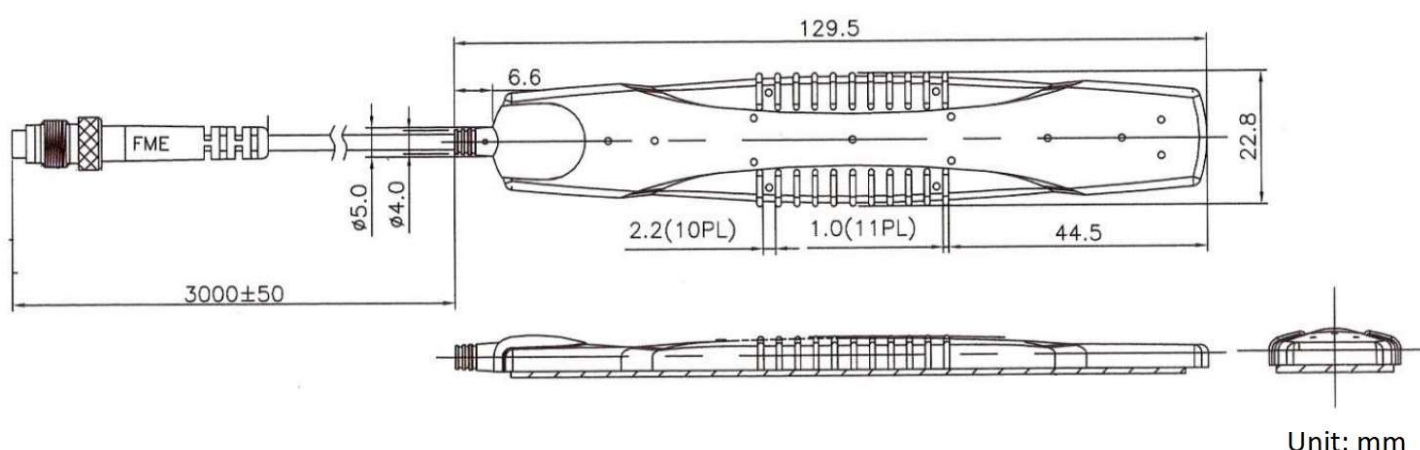

ALL VARIANTS

Different connector variants or cable lengths are available on request.

CONTACTS

SECTRON s.r.o. Josefa Šavla 1271/12
709 00 Ostrava 9, Czech Republic

WWW.SECTRON.CZ
Tel.: +420 556 621 021