



ANTENNA BASE

Magnetic base for antenna
with SMA(f) LMH100 cable
with SMA(m) connector

AO-ABASE-C16-100

SECTRON company offers a wide portfolio of antennas with various versions differing in shape, level of gain and manner of attachment. SECTRON guarantees a compatible connection between an antenna and all antenna adaptors produced by SECTRON.



BENEFITS

- Easy installation
- Low attenuation
- Strong magnetic attachment
- Extended cable length
- High frequency range – suitable for LTE antennas

FEATURES

AO-ABASE-C16-100

Frequency bands	GSM/UMTS/LTE
Impedance	50 Ohm
Max. Base attenuation	< 3.15 dB/3 GHz/3 m
VSWR	< 1.3:1 /3 GHz
Dimensions	Ø 50 x 38.3 mm
Weight	136.2 g
Operating temperature	-30 to +90 °C
Execution	External
Method of attachment	Magnetic
Cable type	LMH100
The cable length	3 m
Connector type	SMA(m)
Connector for antenna	SMA(f)
Certification	ISO 9001, ISO 14001
Material	PP PVC 40P

DRAWING

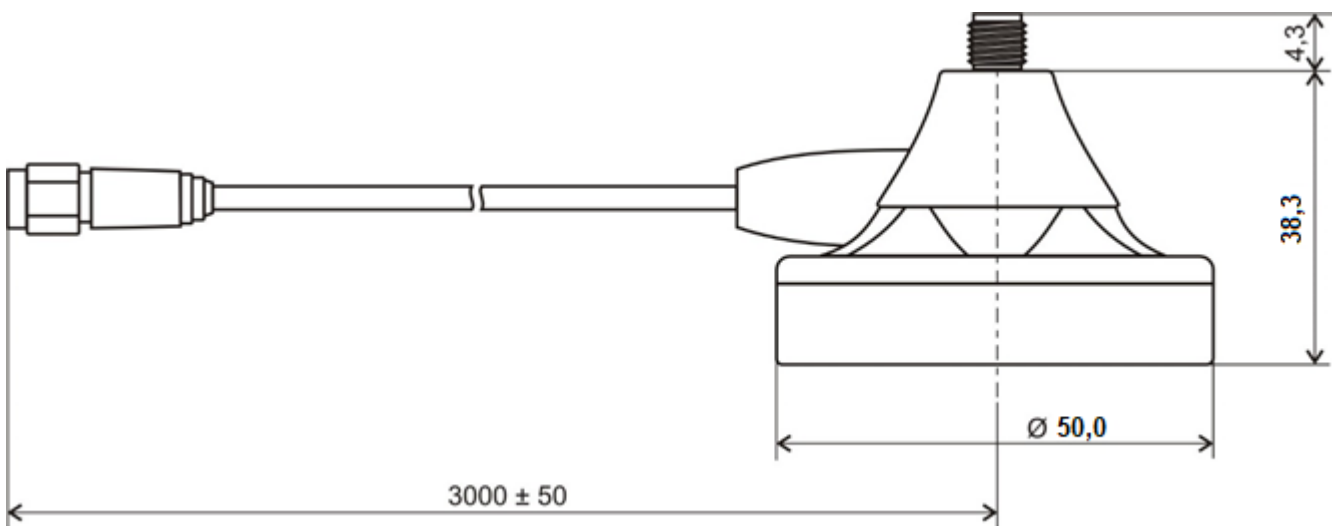

UNIT: mm

GRAPH S21 – Base Attenuation [dB]

Tr3 S21 dB Mag 0.5 dB/Ref -3 dB Cal Smo

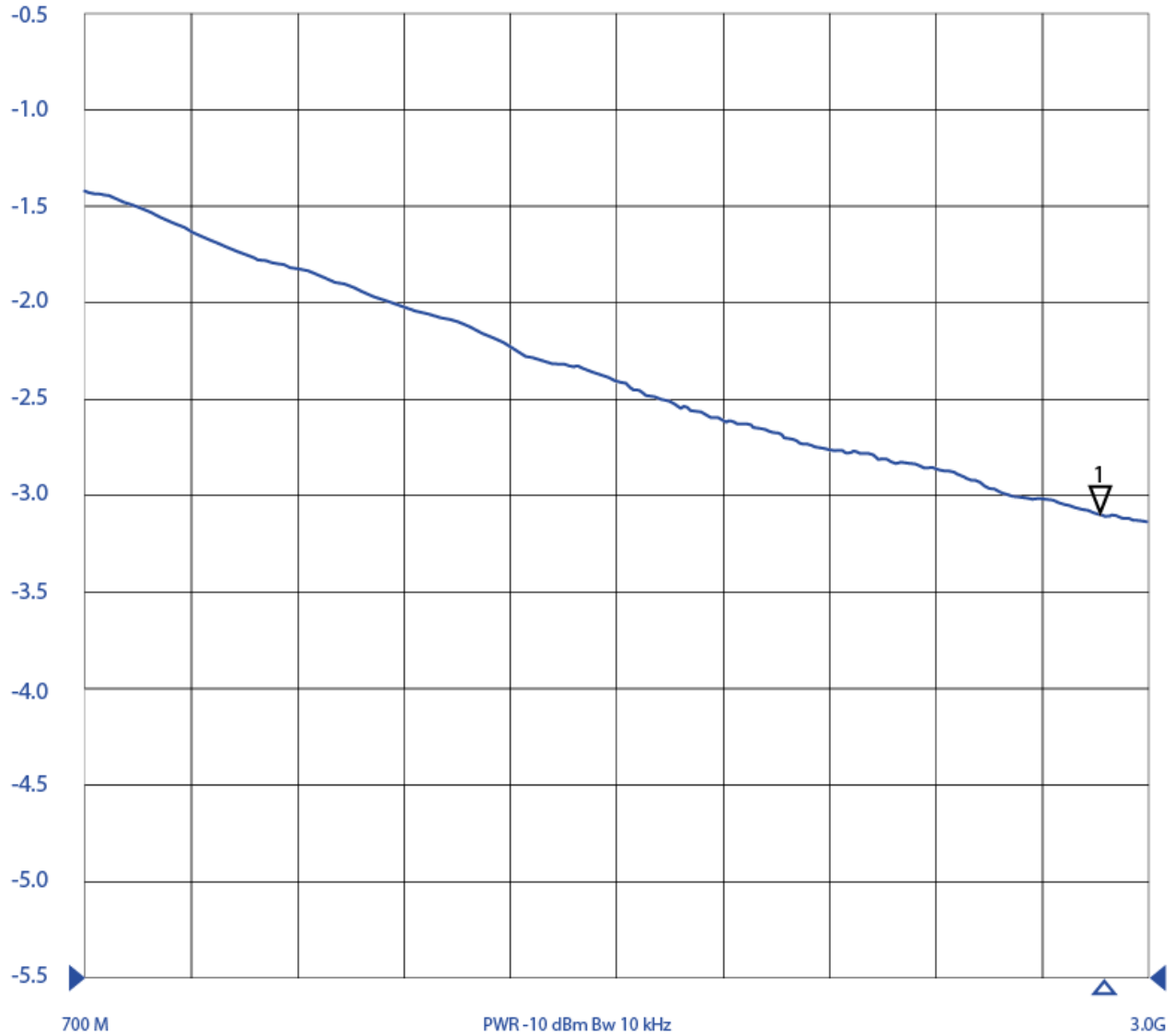

Frequency [MHz]	AO-ABASE-C16-100-S ₂₁ [dB]
690	-1.38
800	-1.47
900	-1.64
1800	-2.36
1900	-2.44
2100	-2.64
2300	-2.8
2400	-2.88
2600	-2.85
2700	-2.99

GRAPH VSWR [-]

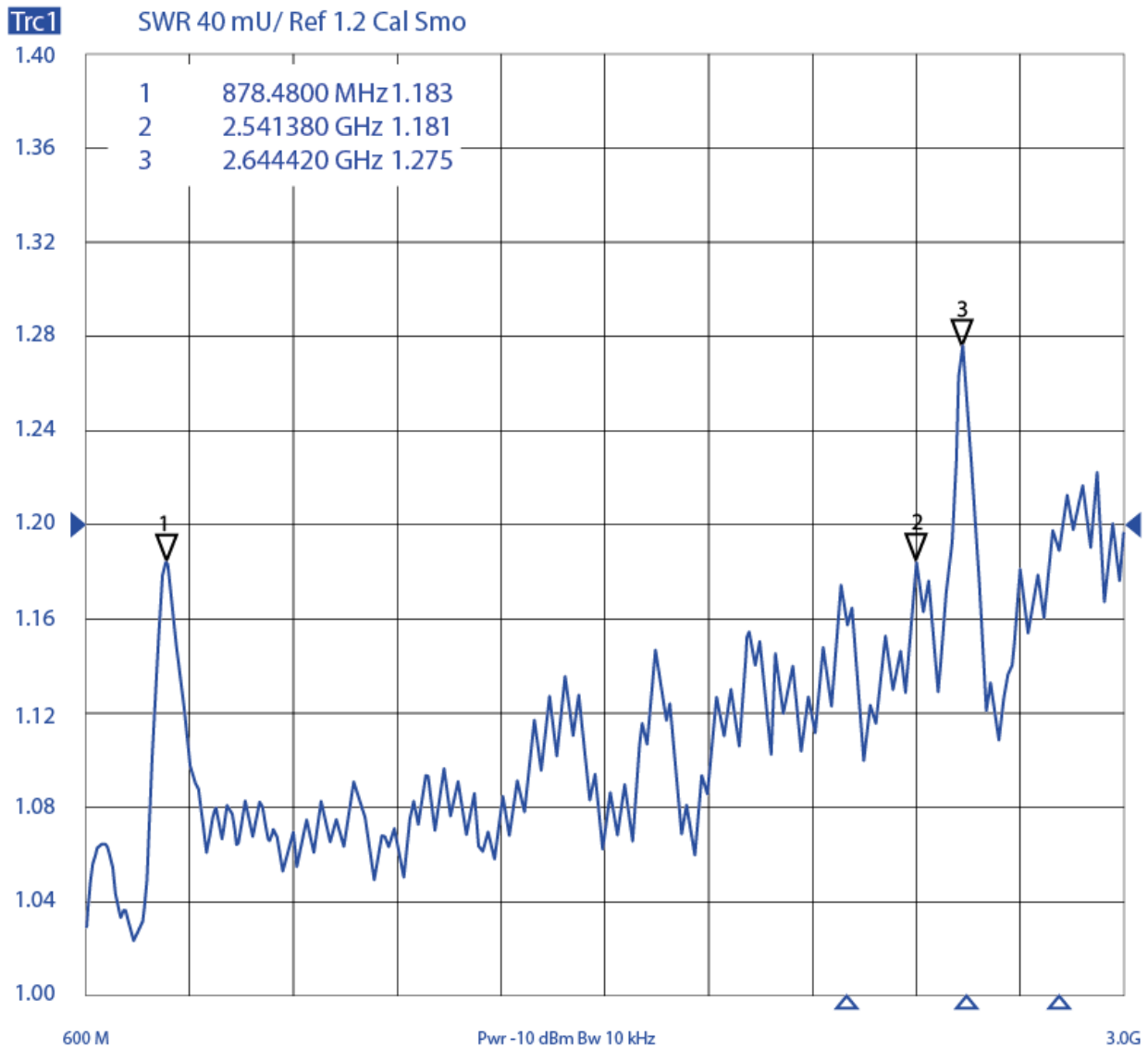

VARIANTS

Different connector variants or cable lengths are available on request.

CONTACTS

SECTRON s.r.o. Josefa Šavla 1271/12
709 00 Ostrava 9, Czech Republic

WWW.SECTRON.CZ
Tel.: +420 556 621 020